



SWITCH GEAR & CONTROL

SGC Series



Valve Regulated Lead Acid (VRLA) Battery Series
Ideally Suited for Switchgear & Control Applications

APPLICATIONS

- Battery Change-Out Trucks
- Electric Utility Substations
- Telephone Backup
- Microwave Sites
- Signaling Sites
- Offshore Platforms

FEATURES & BENEFITS

HIGH RELIABILITY

- Thermally welded case-to-cover bond for hermetic, leak free seal
- Molded in terminal bushing for durability and leak free seal
- Thick positive grids and superior grid alloy for improved high temperature performance and longer life
- UL-recognized component
- Complies with UL1778, UL924, UL1989 and UL94

SAFE OPERATION

- Flame-arresting one-way pressure-relief vent for safety and long life
- Flame-retardant polypropylene case and cover compliant with UL94 V-0 with an Limiting Oxygen Index greater than 28.
 - Self-extinguishing features for added protection
- Can be used in rooms with normal ventilation mounted on racks or in cabinets. A separate battery room is not required.
- Absorbent Glass Mat (AGM) technology for efficient gas recombination of 99% plus.
 - No free electrolyte – prevents acid spills in case of accidental damage

REDUCED MAINTENANCE

- No electrolyte maintenance required
- Multi-cell design for ease of installation by significantly minimizing connections
- Threaded copper alloy terminal inserts eliminate connection re-torque requirements

EASILY TRANSPORTED

- Not restricted for air transport - Complies with IATA/ICAO Special Provision A67
- Not restricted for surface transport – classified as non-hazardous material as related to DOT-CFR Title 49 parts 171-189
- Not restricted for water transport – Classified as non-hazardous material, complies with IMDG exception 238

WARRANTY

- 2 years full + 8 pro-rated

SPECIFICATIONS

Cells Per Unit	6
Voltage Per Unit	12
Operating Temperature Range (with temperature compensation)	Discharge: -40°F (-40°C) to +160°F (71°C) Charge: -10°F (-23°C) to +140°F (60°C)
Normal Operating Temperature Range	+74°F (23°C) to +80°F (27°C)
Recommended Maximum Charging Current Limit	C/5 amperes @ 20 hr rate
Float Charging Voltage	13.5 to 13.8 VDC/unit average at 77°F (25°C)
Equalization and Cycle Service Charging and Current Limits	14.4 to 14.8 VDC/unit average at 77°F (25°C)
Maximum AC Ripple (Charger)	0.5% RMS or 1.5% P-P of float charge voltage recommended for best results Maximum voltage allowed = 4% P-P Maximum current allowed = C/20 RMS
Self Discharge	Up to 6 months at 77°F (25°C) and then a freshening charge is required. Batteries stored at temperatures at greater than +77°F (25°C) will require recharge sooner than batteries stored at temperatures less than 77°F (25°C). See C&D brochure 41-7272, Self Discharge and Inventory Control for details.
Accessories	Rack systems are available for all models
Terminal: Inserted	Threaded copper alloy insert terminal to accept 10-32 UNF x 3/8 in. long screws (SGC 12-30 & SGC 12-45) 1/4-20 UNC x 3/4 in. long screws (SGC 12-70, SGC 12-80, SGC 12-90, and SGC 12-125)
Terminal Hardware Torque	25 in.-lbs (2.8 N-m) (SGC 12-30 & SGC 12-45) 110 in.-lbs (12.4 N-m) (SGC 12-70, SGC 12-80, SGC 12-90, and SGC 12-125)

Model	Rated Battery Capacity @ 8 hr rate to 1.75 volts per cell @ 77°F (25°C)	Maximum Discharge Current	Short Circuit Current @ 0.1 sec	Ohms Impedance 60 Hz (Ω)	Weight (lbs)	Weight (kg)
SGC 12-30	30.4 Ah	500 Amps	2150 Amps	0.0100 Ohms	27.3	12.4
SGC 12-45	45.5 Ah	600 Amps	2500 Amps	0.0060 Ohms	40.6	18.4
SGC 12-70	69.1 Ah	800 Amps	3100 Amps	0.0050 Ohms	55.8	25.3
SGC 12-80	79.0 Ah	800 Amps	3300 Amps	0.0040 Ohms	66.6	30.2
SGC 12-90	87.6 Ah	800 Amps	3600 Amps	0.0035 Ohms	74.5	33.8
SGC 12-125	126.0 Ah	800 Amps	5000 Amps	0.0023 Ohms	102.3	46.4

DIMENSIONS

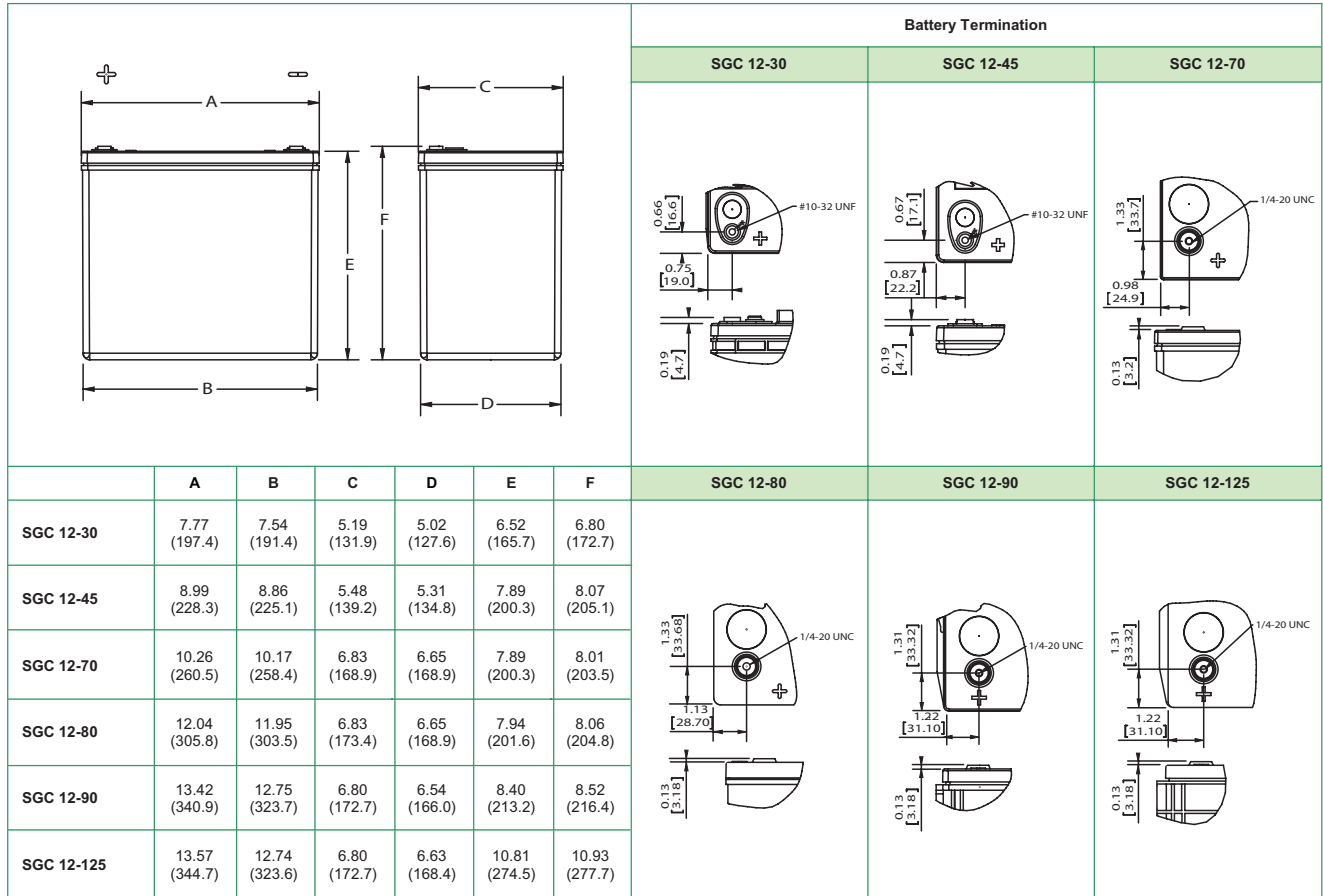

All dimensions in inches and (millimeters). All dimensions are for reference only. Contact a C&D Representative for complete dimension information.

RACK SELECTION MATRIX



For more details:

- See 41-6977, RB Rack Selection Guide
- See 41-6976, RB Rack Assembly Instruction

System DC Voltage	Number of Batteries per System	Use with Battery Model		Use with Battery Model		Number of Tiers Per Rack	Number of Racks To Order per System	Empty slots per system
		SGC 12-30	SGC 12-70	SGC 12-30	SGC 12-70			
		SGC 12-45	SGC 12-80	SGC 12-45	SGC 12-90			
		Non-Seismic (Zone 0) Rack Model		Seismic (Zones 1-4) Rack Model				
48 V (4 Jars)	4	RBN1T	RBW1T	RBN1TEQ	RBW1TEQ	1	1	1
120 V (10 Jars)	10	RBN1T	RBW1T	RBN1TEQ	RBW1TEQ	1	2	0
		RBN2T	RBW2T	RBN2TEQ	RBW2TEQ	2	1	

RATINGS PER CELL

Models	End Point Volts/Cells	Constant Current Discharge Ratings @ 77°F (25°C)									
		Amperes									
		1 min	15 min	30 min	1 hr	2 hr	3 hr	4 hr	5 hr	8 hr	12 hr
SGC 12-30	1.75	137.8	59.3	36.2	22.1	13.0	9.2	7.2	5.8	3.8	2.7
	1.80	128.0	56.2	34.5	21.0	12.4	8.8	6.9	5.6	3.7	2.6
	1.85	116.0	51.5	32.1	19.6	11.6	8.4	6.6	5.4	3.5	2.5
	1.90	104.2	47.9	29.9	18.5	11.1	8.0	6.4	5.2	3.4	2.4
SGC 12-45	1.75	156.0	79.9	51.8	31.5	18.5	13.2	10.3	8.5	5.7	4.0
	1.80	138.0	71.5	47.7	30.0	18.0	13.0	10.0	8.2	5.5	3.9
	1.85	113.4	63.7	43.9	28.0	17.4	12.7	9.9	8.1	5.4	3.8
	1.90	89.6	54.4	39.4	26.2	16.5	12.2	9.5	7.8	5.2	3.6
SGC 12-70	1.75	198.8	117.3	75.7	46.8	27.5	19.8	15.6	12.9	8.6	6.0
	1.80	178.9	108.0	71.0	44.5	26.8	19.2	15.0	12.3	8.4	5.9
	1.85	163.4	100.1	66.3	41.8	25.5	18.3	14.3	11.9	8.1	5.6
	1.90	147.1	89.4	61.2	39.5	24.2	17.3	13.6	11.3	7.7	5.4
SGC 12-80	1.75	302.0	140.0	88.4	53.8	31.5	22.6	17.5	14.5	9.9	6.9
	1.80	264.7	128.6	81.8	51.1	29.8	21.6	17.0	14.0	9.6	6.7
	1.85	212.0	117.2	77.4	47.0	27.5	20.3	16.1	13.4	9.1	6.4
	1.90	172.4	103.8	67.5	43.0	25.4	18.5	15.0	12.5	8.5	5.9
SGC 12-90	1.75	331.1	159.4	102.3	60.0	34.8	25.0	19.8	16.2	11.0	7.8
	1.80	273.7	145.1	92.6	57.0	33.0	24.0	19.0	15.6	10.6	7.6
	1.85	234.6	130.1	85.5	53.3	31.4	22.8	18.0	15.0	10.1	7.2
	1.90	185.9	115.2	78.8	49.5	29.9	21.7	17.1	14.2	9.5	6.7
SGC 12-125	1.75	445.3	221.3	145.2	87.5	49.0	36.0	28.4	23.6	15.8	10.8
	1.80	370.8	202.1	135.3	82.5	47.3	34.7	27.5	22.7	15.2	10.6
	1.85	309.0	186.4	121.7	77.0	44.0	32.5	26.3	21.8	14.5	10.1
	1.90	275.0	172.1	113.4	71.0	41.5	30.7	24.3	20.2	13.4	9.4

LCT II 1700



Liberty 1000



SAGEON



DYNASTY

MCT II

A CENTURY OF EXPERIENCE YOU CAN TRUST

From our inception over 100 years ago, C&D Technologies has been a pioneer in the development of energy storage and power conversion systems that enable telecommunications, data transmission, computer system infrastructure and utilities to maintain critical operations during power outages. C&D supplies batteries and power plants to the leading telecommunications companies, from the smallest outside plant and wireless sites to the largest major central office switch facilities preventing loss of traffic and associated revenue. Our batteries and chargers are used in electrical power generation plants and substations for major electric utility companies, preventing damage to expensive infrastructure equipment. C&D batteries are used in large data centers, network operations centers, financial institutions and many other sites that depend on uninterruptible power supplies to maintain power to their critical equipment. To this day, C&D continues to be the industry leader providing the highest quality products, including reliable long lasting batteries for most industrial and commercial standby power applications. Our web site www.cdtechno.com provides product data and contact information for our local representatives and branches, located in over 40 countries. Our continued success is due to many factors including our products, our employees and our sales partners. But mostly, C&D's success is due to the loyalty of our customers, for which we are thankful.



Global Corporate Headquarters
200 Precision Rd.
Horsham, PA 19044
USA

customersvc@cdtechno.com
www.cdtechno.com

Any data, descriptions or specifications presented herein are subject to revision by C&D Technologies, Inc. without notice. While such information is believed to be accurate as indicated herein, C&D Technologies, Inc. makes no warranty and hereby disclaims all warranties, express or implied, with regard to the accuracy or completeness of such information. Further, because the product(s) featured herein may be used under conditions beyond its control, C&D Technologies, Inc. hereby disclaims all warranties, either express or implied, concerning the fitness or suitability of such product(s) for any particular use or in any specific application or arising from any course of dealing or usage of trade. The user is solely responsible for determining the suitability of the product(s) featured herein for user's intended purpose and in user's specific application.