



PowerSafe[®] EC-M

Switchgear, Telecommunications and Utility

Battery Performance Specifications



Visit us at www.enersys.com



RESERVE
POWER

Publication No: US-ECM-PS-AA August 2016

Features and Benefits

- Capacity range 215 - 850Ah
- Lead-calcium alloy
- Standard Styrene Acrylonitrile (SAN) jar with flame retardant UL94 V-0 PVC cover; PC flame retardant jar and cover optional
- Thick positive plates maximize performance in long discharge applications
- 20 year life expectancy in float service at 77°F (25°C) ambient temperature

Construction

- 0.34" thick positive plates provide excellent long discharge rates and long life
- Negative plate design enhances high rate performance
- Separator – microporous rubber with "Vitrex" glass fiber retainers
- Electrolyte – dilute sulfuric acid with specific gravity of 1.215 (1.250 available upon request)
- Copper inserted posts
- Slide-Lock™ post seal design
- Flame arrestors – included for increased operational safety

Installation and Operation

- Tin plated copper inter-cell connectors (standard); lead plated optional
- Dual posts for high current carrying capability (EC-15M and above)
- Excellent long discharge and complex duty cycle capability for switchgear applications
- 20 year life expectancy in float service at 77°F (25°C)
- Post design features low resistance copper inserts for high rate performance
- Operating temperature: 32°F (0°C) to 104°F (40°C)
Recommended temperature: 68°F (20°C) to 86°F (30°C)

Standards

- The management systems governing the manufacture of this product are ISO 9001:2008 and ISO 14001:2004 certified

General Specifications

Cell Type	Nominal Ah Capacity*	Nominal Dimensions						Weight - Volumes						Short Circuit Current (Amps)
		Length**		Width		Height		Unpacked		Electrolyte only/1.215 SG				
		in	mm	in	mm	in	mm	lbs	kg	lbs	kg	gal	L	
EC-5M	215	5.1	130	11.0	279	18.7	475	60.9	27.7	20.9	9.5	2.1	7.8	2290
EC-7M	290	5.1	130	11.0	279	18.7	475	71.9	32.7	18.9	8.6	1.9	7.1	3370
EC-9M	365	5.1	130	11.0	279	18.7	475	82.7	37.6	16.9	7.7	1.7	6.4	4420
EC-11M	470	6.6	168	11.0	279	18.7	475	103.8	47.2	24.0	10.9	2.4	9.0	5620
EC-13M	525	6.6	168	11.0	279	18.7	475	113.7	51.7	20.0	9.1	2.0	7.5	6450
EC-15M	620	8.1	206	11.0	279	18.7	475	139.7	63.5	29.0	13.2	2.9	10.8	7530
EC-17M	670	8.1	206	11.0	279	18.7	475	149.6	68.0	26.8	12.2	2.7	10.1	8840
EC-19M	795	10.1	257	11.0	279	18.7	475	175.6	79.8	37.0	16.8	3.7	13.8	9140
EC-21M	850	10.1	257	11.0	279	18.7	475	186.6	84.8	35.9	16.3	3.6	13.5	9760

*Nominal Ah capacity is based on an 8 hour rate to 1.75 volts per cell @ 77°F(25°C)
 **0.25" must be added between cells for spacing purposes when calculating total battery rack length.

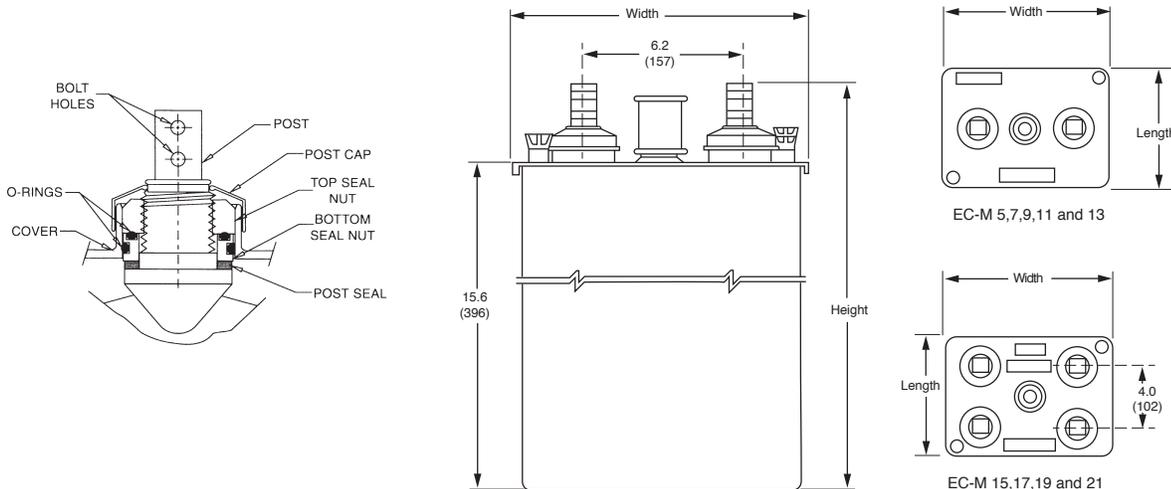

Battery Performance Specifications

Rint and Isc

Cell Type	*Resistance	Isc
	Milliohms	Amps
EC-5M	0.875	2290
EC-7M	0.593	3370
EC-9M	0.453	4420
EC-11M	0.356	5620
EC-13M	0.310	6450
EC-15M	0.266	7530
EC-17M	0.226	8840
EC-19M	0.219	9140
EC-21M	0.205	9760

Constant Current

1.215 Specific Gravity

Discharge Rates in Amperes to 1.75Vpc at 77°F (25°C)

Cell Type	Nominal Ah Capacity*	Minutes			Hours									
		1	15	30	1	1.5	2	3	4	5	8	12	24	72
EC-5M	215	253	180	140	100	80	67	52	43	37	27	20	12	6
EC-7M	290	364	266	204	144	113	95	72	59	51	36	27	16	7
EC-9M	365	475	351	269	188	147	122	93	76	65	46	33	20	8
EC-11M	470	594	443	340	239	187	155	118	96	82	58	42	25	11
EC-13M	525	694	511	392	274	214	177	134	109	93	65	47	28	11
EC-15M	620	812	596	455	318	249	207	157	128	110	78	56	33	14
EC-17M	670	925	690	525	364	283	233	176	142	120	84	60	34	14
EC-19M	795	981	741	573	405	318	265	202	165	141	100	72	43	18
EC-21M	850	1068	802	625	443	349	290	220	179	152	106	76	45	18

Discharge Rates in Amperes to 1.81Vpc at 77°F (25°C)

Cell Type	Nominal Ah Capacity*	Minutes			Hours									
		1	15	30	1	1.5	2	3	4	5	8	12	24	72
EC-5M	215	183	150	120	90	73	62	49	41	36	26	20	12	6
EC-7M	290	264	219	175	128	103	87	68	56	48	35	26	16	7
EC-9M	365	344	289	229	166	133	112	86	71	61	44	32	19	8
EC-11M	470	425	364	290	211	169	143	110	91	78	56	41	25	10
EC-13M	525	497	421	334	242	193	162	125	103	88	62	46	27	11
EC-15M	620	589	493	389	282	226	190	147	121	104	74	55	33	14
EC-17M	670	659	567	448	322	256	214	163	134	114	80	58	34	14
EC-19M	795	707	607	487	357	287	242	188	155	133	95	70	42	18
EC-21M	850	774	664	534	395	317	267	206	169	145	103	75	44	18

*Nominal Ah Capacity is based on an 8 hour discharge rate



www.enersys.com

EnerSys World Headquarters 2366 Bernville Road, Reading, PA 19605, USA Tel: +1-610-208-1991 / +1-800-538-3627

EnerSys EMEA EH Europe GmbH, Baarerstrasse 18, 6300 Zug, Switzerland Tel: +41 44 215 7410

EnerSys Asia 152 Beach Road, Gateway East Building #11-03, Singapore 189721 Tel: +65 6508 1780

© 2016 EnerSys. All rights reserved.

Trademarks and logos are the property of EnerSys and its affiliates except Slide-Lock™ which is not the property of EnerSys. Subject to revisions without prior notice. E.&O.E.

Publication No: US-ECM-PS-AA August 2016