

ORDERING GUIDE

# GPS 2436 Infinity Power System

+24V DC Medium Power Plant

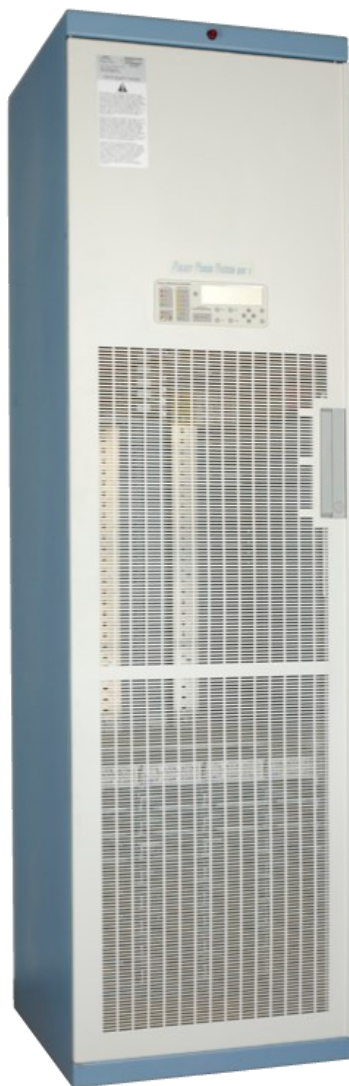

---

# Table of contents

03 – 03	Overview
04 – 04	Key Features
09 – 09	Specifications
14 – 25	Ordering Guides Information

# GPS 2436 Infinity Power System

## +24V DC Medium Power Plant

- Medium power applications utilizing single-phase or 3-phase 240Vac input
- Full featured control and monitoring capability
- 3600 Amp system capacity
- Efficiency approaching 97%

### Overview

The GPS2436 capitalizes on the product strengths found in the GPS4848 and Infinity product families by integrating the high efficiency Infinity TE rectifier platform and the time-tested distribution found in the GPS4848. Utilizing the 1U 100A 24Vdc rectifiers, a fully equipped bay only requires 15.75 inches allowing for as much as 60 inches of distribution panels. With this increased density, a single bay GPS2436 system provides ampacity and distribution for most medium and small applications while retaining all the features found with the larger GSP4848.

### Bay Options

The GPS2436 system can be deployed with capacity of up to 2400 amps in a single cabinet or expanded over multiple cabinets to 3600 amps. Designed for either internal input AC breakers or terminal strip terminations, rectifier shelves can be spread across two bays or concentrated to a single bay. In applications needing additional distribution, two more bays can be added and dedicated exclusively for distribution.

### Infinity Rectifiers

The Infinity TE rectifier series offers modules for use in +24Vdc applications.

#### Rectifier:

- NE100AC24ATEZ Rectifier, 100A/24V Output

### Galaxy Millennium® II & Pulsar Plus Controllers

The Galaxy Millennium II controller combines sophisticated power monitoring and remote management. This flagship controller simplifies operations and maintenance while lowering administrative costs. Remote peripheral modules support over 500 monitoring points for ABB or third party devices. Ethernet, SNMP, and TL1 provide integration with power engineering and NOC workflow.

As an economical alternative, the GPS2436 can be equipped with the Pulsar Controller. Designed to monitor and control system components including rectifier's converters and distribution modules via a multi-drop RS485 digital communications bus. System status, parameters settings and alarm thresholds can be viewed and configured from the controller's front panel or PC interface.

### Benefits

#### Reliability

- Distributed fault tolerance
- Proven field performance
- Controller continuity

#### Intelligence

- Industry leading controller features
- Ethernet interface for remote access
- Centralized network management

#### Investment Protection

- Module compatibility
- Power shelf growth
- Flexible upgrade options

#### On Time Delivery

- 4 – 6 week availability
- 24/7 technical support
- Standard building blocks

## Total Efficiency

The ABB Energy Total Efficiency™ (TE) architecture reduces energy loss and lowers cooling costs by 50-70%. TE products will prioritize sustainable energy sources like solar, wind, water and fuel cells over traditional utility grid or diesel generator sources – and they will intelligently respond to smart grid information to reduce consumption during peak demand periods. Active Rectifier Management™ (ARM) and Battery Charging Optimization™ (BCO) features increase efficiency on current and legacy power infrastructures. The Total Efficiency architecture addresses issues end-to-end based on our proven experience and expertise in batteries, power distribution, DC energy systems, AC-DC power supplies, and DC-DC board mounted power to deliver a solution that is more safe, reliable and energy efficient than competitive alternatives.

## Infinity TE Rectifiers

**Compact** - 1RU form factor providing high power density (24 W/in<sup>3</sup>)

**Plug and Play** – installation of the rectifier in a shelf connected to a compatible system controller initializes all set up parameters automatically. No adjustments are needed.

**Extended service life** – parallel operation with automatic load sharing

ensures that parallel units are not unduly stressed even when a unit fails or is removed.

**Monitoring / control** – the built in microprocessor controls and monitors all critical rectifier functions and communicates with the system controller using the built in Galaxy Protocol serial interface.

**Fail safe performance** – hot insertion capabilities allow for rectifier replacement without system shutdown; soft start and inrush current protection prevent nuisance tripping of upstream breakers.



### Applications

- Telecommunications networks
- Digital subscriber line (DSL)
- Indoor/outdoor wireless
- Routers/switches
- Fiber in the loop
- Transmission
- Data networks
- PBX

### Key Features

- Extended temperature range
- Redundant fan cooling
- Front panel LED indicators
- 1U height, hi power density
- +24 or -48V input
- Digital load sharing
- Hot pluggable
- RoHS compliant

## Specifications

Input		NE100AC24ATEZ
Voltage Range		95-275Vac
Input Current		15-12A @100-120Vac,15A @200-240Vac
Input Frequency		45–66Hz
Power Factor		0.98 @ >50% load
Efficiency		> 96% (Peak 96.9%)
Total Harmonic Distortion		< 5% @loads over 50%
Output		
Voltage Adjust Range		21-29Vdc
Voltage Nominal		27.25V
Regulation (with controller)		±0.5%
Ripple		100mVrms
Output Current	High-Line	100A @27.25V
	Low-Line	44A @27.25V
Heat Dissipation @ max out		174W / 594 BTU/hr

### Environmental

Operating Temperature	-40°C to +75°C (-40°F to 167°F)
Storage Temperature	-40°C to +85°C (-40°F to 185°F)
Humidity	< 95% non-condensing
Altitude	2000M max

### Mechanical

Length (inch/mm)	13.85 / 352
Width (inch/mm)	5.23 / 133
Height (inch/mm)	1.63 / 42
Weight (lb/Kg)	5.05 / 2.2

### Safety and Standards Compliance

NEBs Level 3	Evaluated by independent NRTL test lab to Telcordia GR63, Issue 3 & GR 1089, Issue 5
Safety	UL 62368-1, 2nd Ed. Recognized CSA C22.2 No. 60950-1-03 Certified
RoHS	Compliant to RoHS Directive 2011/65/EU and amended Directive (EU) 2015/863.
EMC	European Directive 2004/108/EC; EN55032, Class A; EN55024; FCC, Class A; GR1089-CORE, Issue 5

### Outline Drawing

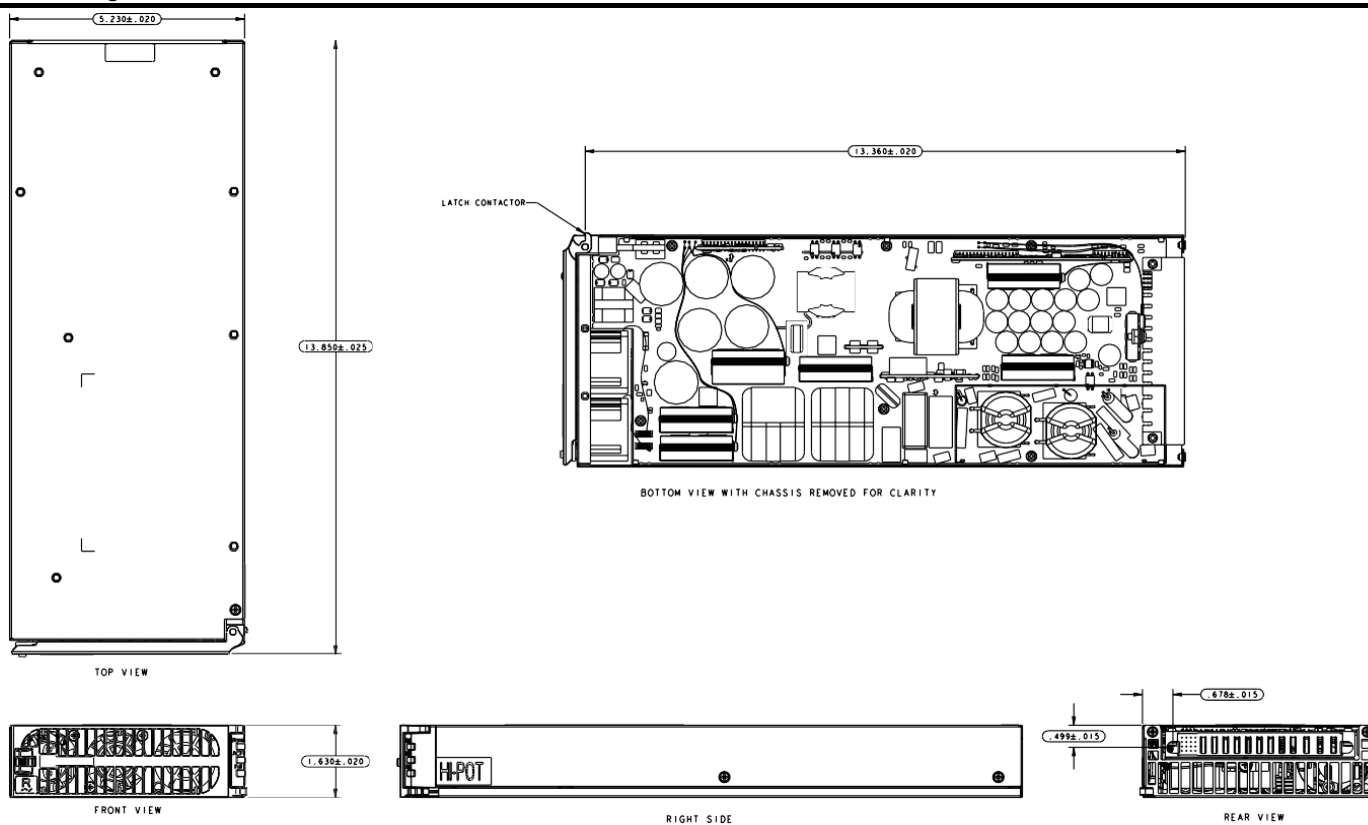

## Galaxy Millennium™ II Controller

Galaxy Millennium II is our flagship controller designed to meet the needs of the most advanced power systems. Building on the Galaxy Millennium platform, the Galaxy Millennium II delivers state-of-the-art performance by combining sophisticated control, monitoring, and remote network access previously on three separate circuit packs into a single integrated unit. The controller has been designed to simplify plant administrative and surveillance routines as well as reduce operating, provisioning, and personnel expenses.



Configuration of the Galaxy Millennium II can be performed via menu based front panel display, a local terminal or remote modem using EasyView2, or through a local or remote network connection utilizing standard web browsers or network protocols. In addition to its standard integrated monitoring capabilities, this controller offers extensive external monitoring using bay interface cards (BICs), distribution control cards, and remote peripheral monitoring modules (RPMs) designed for various inputs and transducers. Additional external relay contacts are also available.

The Galaxy Millennium II, with integrated network access, allows for advanced network supervision using standard network management protocols and available network management software. The ABB Energy Galaxy Manager network management software can be used to meet power system engineering, operations and maintenance needs. Via the World Wide Web, users gain access to live data and information logged into Galaxy Manager's centralized server from each monitored system controller across the power network.

### Applications

- Infinity NE-M
- CPS6000-M2
- GPS 4848/100
- Galaxy Vector controller upgrades
- GPS 4812/24
- GPS 2424
- Stand-alone monitoring applications
- Galaxy Millennium upgrades & replacements
- FTP for rapid backup and upgrades
- HTTP for standard and custom web pages for standard browsers
- Compatible with Galaxy Manager and other standard network management packages
- Standard shielded RJ-45 interface referenced to chassis ground
- Optional Data switch

### Key Features

#### Remote Access and Features

- Integrated 10/100Base-T Ethernet Network capability
  - TCP/IP
  - SNMP Version 2c for remote management
  - SMTP for email
  - Telnet for remote command line interface
  - TL-1
  - DHCP for network plug-n-play
- Connections to 3 standard RS-232 devices for pass-through and alarm management
- BSN extension to provide 3 additional RS-232 serial connections
- Configurable RS-232/485 port for remote via TL1/X.25
- EasyView2, Windows-based software, for configuration and reporting through local terminal or Modem connections
- Multiple password-protected security levels: User, Super-User, Administrator for all access

## Standard System Features

- Monitoring and control of up to 85 RS485 serial connected devices
  - Maximum of 85 serial switch mode rectifiers
  - Maximum of 32 bay interface cards (BICs)
  - Maximum of 16 serial converters
- Standard and custom User Defined system alarms
  - Alarm cut-off
  - Alarm test
  - Multiple-level alarm severity: Critical, Major, Minor, Warning, and record-only
- Standard rectifier management features
  - Automatic rectifier restart
  - Reserve engine transfer
  - Adaptive Rectifier Management (ARM)/Energy Efficiency
  - Remote rectifier (on/off) control
  - Automatic rectifier sequence control
  - N + X redundancy check
- Low Voltage Load and Low Voltage Battery Disconnect Options (3)
- Various levels of configuration, statistics, and history
  - All stored in non-volatile memory
  - Remote and local backup and restore of configuration data
- Remote and local software upgrade
- Basic, busy hour, and trend statistics kept
- Detailed history kept
- Maintenance reminders
- Inventory management
- User defined events and derived channels
- Hardware DIP switch access control

## Standard Battery Management Features

- Float/boost mode control
  - Manual front panel boost
  - Manual timed boost locally, T1.317, and remotely initiated
  - External timed boost
  - Battery thermal protect module (BTP)
  - Auto boost terminated by time or current
- Battery discharge testing
  - Manual
  - Periodic
  - Plant Battery Test (PBT) input driven
- Slope thermal compensation
  - High temperature compensation
  - Low temperature compensation
  - Step temperature
  - STC Enable/Disable, low temperature Enable/Disable
  - mV/°C adjustments
- High temperature disconnect/step setting
- Sophisticated reserve-time prediction
  - User configurable system reserve low alarm during normal operation
  - User configurable reserve time low alarm
- Recharge current limit
- Integrated “At Rate Calculator” for estimation purposes
- Battery discharge trace data
- Emergency Power-Off Input
- Lithium battery fail input

## Features

### Integrated Outputs

- Traditional office alarm interface with 19 Form-C alarm outputs (60VDC @.3A)
  - Standard default assignments: Power Critical-Audio, Power Critical-Visual, Power Critical-External, Power Major-Audio, Power Major-Visual, Power Major-External, Power Minor-Audio, Power Minor-Visual, Power Minor-External, Major Fuse (MJF), Minor Fuse (MNF), Battery On Discharge (BD), AC Fail (ACF), Rectifier Fail, High Voltage (HV), Very Low Voltage (VLV), Controller Fail, User Relay 1, User Relay 2
  - 16 Form-Cs are user assignable
- 1 1/3A Auxiliary Battery Supply (ABS) Output

### Remote Peripheral Monitoring & Control

- Modular monitor and control growth options for up to 95 monitoring modules optimized for DC voltage and shunt monitoring, binary input detection, temperature monitoring, external transducer monitoring
- Additional Form-C relay output control available
- Devices managed and powered by the controller via one twisted-pair cable over distances of 300m or more
- Daisy-chain connections from module to module reduce installation costs and cable congestion
- Modules can be located near monitored source
- Various panels for rack-mounting available

### Enhanced Battery Management Features

- Battery discharge test options including periodic and manual tests (local/ remote) with configurable thresholds or 20% discharge algorithm
- State of charge indication
- Rectifiers on-line during test (minimize risk to service)

- Discharge data stored in non-volatile memory. Graphical data available
- Accurate battery reserve time calculations that factor in battery specific parameters, plant voltage, load, temperature, number of battery strings and number of cells per string
- Thermal compensation (STC) and recharge current limit to maximize battery life

### Extensive Plant and Monitoring Statistics

- Real-time data and historical statistics help analyze critical performance parameters
- Statistics for planning preventive or corrective maintenance before serious problems occur

### Derived Channels

- 32 derived channels enable arithmetic and Boolean operations to be performed on measured values to allow customer specific parameters such as output power to be calculated and managed

### Rectifier Management

- Energy Efficiency, provides ability to automatically shutdown selected rectifiers during low plant loads maintaining maximum battery plant efficiency without sacrificing reliability
- Provides Reserve Operation feature for maintaining designated number of rectifiers on during Engine runs as well as proper sequencing for generators
- Provides ability to transfer rectifiers (TR1-TR4) on in certain sequences for return of AC

### Galaxy Manager Compatible

- Centralized web server and database with multiple user access to live or managed data with drill down to problem details



- Monitor and control of more than 40 connected devices
- Management information from polling or alarms received from alarm traps from multiple sites are available on one screen via the inter/ intranet
- Trend user selected data over time
- Automatic or manual report generation
- Standard engineering tools like reserve time calculators and cable voltage drop analyzer

## Specification

### General

Operating Voltage	± 24Vdc, ± 48Vdc (Range: ± 18 to ±60Vdc)
Input Power	36W (depending on options)
Operating Temperature Range	-40°C to +75°C (-40 to 167°F)
Storage Temperature Range	-40°C to +85°C (-40 to 185°F)
Operating Relative Humidity	0 - 95% (non-condensing)
Physical Specifications	9.24" H x 20.76" W x 2.14" D
Display	8-line by 40-character backlit LCD

### Agency Certifications

NEBs	Evaluated by independent NRTL test lab to Telcordia GR63, Issue 3 and GR1089-CORE, Issue 5 (including level 3 testing)
EMC (Emissions)	FCC and EN 55032, Class B; FCC, Class B; GR1089-CORE, Issue 5
Safety	UL Listed Component as Part of GPSPower System

## Pulsar Plus Controller

The Pulsar Plus family of controllers provides system monitoring and control features for Infinity, CP, and other power systems. These controllers monitor and control system components including rectifiers, converters, and distribution modules via a multi-drop RS485 digital communications bus. System status, parameters, settings, and alarm thresholds can be viewed and configured from the controller's front panel display. Assignment and configuration of alarm inputs and output relays can be performed from a laptop computer connected to a local RS-232 or Ethernet port, or by remote access is through a network connection to the World Wide Web (internet) or your enterprise network (intranet). An optional modem is also available.



This controller utilizes standard network management protocols allowing for advanced network supervision. ABB Energy Galaxy Manager™ software is the centralized visibility and control component of a comprehensive power management system designed to meet engineering, operations and maintenance needs. The Galaxy Manager client-server architecture enables remote access to system controllers across the power network.

### Applications

- Telecommunications networks
- Digital subscriber line (DSL)
- Indoor/outdoor wireless
- Routers/switches
- Fiber in the loop
- Transmission
- Data networks
- PBX
- Password protected security levels: User, Super-User, Administrator for all access
- Ground-referenced RS232 system port
- ANSI T1.317 command-line interface
- Modem access support
  - Remote via external modem
  - Callback security
- EasyView2, Windows-based GUI software for local terminal or Modem access

### Key Features

#### Remote Access and Features

- Integrated 10/100Base-T Ethernet Network
  - TCP/IP
  - SNMP V2c for management
  - SMTP for email
  - Telnet for command line interface
  - DHCP for plug-n-play
  - FTP for rapid backup and upgrades
  - HTTP for standard web pages and browsers
  - Compatible with Galaxy Manager and other management packages
  - Shielded RJ-45 interface referenced to chassis ground

#### Standard System Features

- Monitor and control of more than 60 connected devices
  - Robust RS485 system bus
- Standard and user defined alarms
  - Alarm test
  - Assignable alarm severity: Critical, Major, Minor, Warning, and record-only
  - 10 alarm relays (7 user assigned)
- Rectifier management features
  - Automatic rectifier restart
  - Active Rectifier Management ARM (energy efficiency)
  - Remote rectifier (on/off)

- Reserve Operation
- Automatic rectifier sequence control
- N + X redundancy check
- Multiple Low Voltage Load and Low Voltage Battery Disconnect thresholds
- Configuration, statistics, and history
  - All stored in non-volatile memory
  - Remote/local backup and restore of configuration data
- Industry standard defaults
  - Customer specific configurations available
- Remote/ local software upgrade
- Basic, busy hour, and trend statistics
- Detailed event history
- User defined events and derived channels

### Standard Battery Management Features

- Float/boost mode control
  - Manual boost
  - Manual timed boost locally, T1.317, and remotely initiated
  - Auto boost terminated by time or current
- Battery discharge testing
  - Manual (local/remote)
  - Periodic
  - Plant Battery Test (PBT) input driven
  - Configurable threshold or 20% algorithm
  - Graphical discharge data
  - Rectifiers on-line during test
- Slope thermal compensation
  - High temperature
  - Low temperature
  - Step temperature
  - STC Enable/Disable, low temperature Enable/Disable
  - Configurable mV/°C slopes
- State of charge indication
- High temperature disconnect setting
- Reserve-time prediction

- Recharge current limit
- Emergency Power-Off input

### Integrated Monitoring Inputs/Outputs

- System plant voltage (accuracy  $\pm 0.04V$ , resolution 0.01V)
- One system shunt (accuracy  $\pm 0.5\%$  full scale, resolution 1A)
  - Battery or load
  - Mounted in the return side of DC bus
- Up to 15 binary inputs
  - Six inputs close/open to battery
  - 9 input close/open to return
  - User assignable
- Up to 7 Form-C output alarms (60VDC @.5A)
  - User assignable
- 1-Wire™ bus devices
  - Up to 16 temperature probes (QS873)
  - Up to 6 mid-string monitors (ES771)

### Galaxy Manager Compatible

- Centralized web server and database with multiple user access to live or managed data with drill down to problem details
- Monitor and control of more than 40 connected devices
- Management information from polling or alarms received from alarmtraps from multiple sites are available on one screen via the inter/ intranet
- Trend user selected data over time
- Automatic or manual report generation
- Standard engineering tools like reserve time calculators and cable voltage drop analyzer

---

## General

---

Operating Voltage	±24 Vdc, ±48 Vdc
Input Power	Less than 7W
Operating Temperature Range	-40°C to +75°C (-40 to 167 °F)
Operating Relative Humidity	0 - 95% (non-condensing)
Storage Temperature Range	-40°C to +85°C (-40 to 185 °F)
Physical Specifications	Sizes vary by packaging option
Display	8-line by 40-character with alarm context sensitive backlit LCD

---

## Safety and Standards Compliance

---

NEBs	Evaluated by independent NRTL test lab to Telcordia GR63, Issue 3 and GR1089-CORE, Issue 5
Safety	CSA C22.2 No. 62368-1-03 Certified for Canada and U.S.; UL60950-1 1st Ed.
RoHS	Compliant to RoHS Directive 2011/65/EU and amended Directive (EU) 2015/863.
EMC	European Directive 2004/108/EC; EN55032, Class A; EN55024; FCC, Class A; GR1089-CORE, Issue 5

---

## Agency Certifications

---

NEB Level 3	Evaluated by independent NRTL test lab to Telcordia GR63, Issue 3 and GR1089-CORE, Issue 5
EMC	European Directive 2004/108/EC; EN55032 (CISPR22) Class A; EN55024 (CISPR24)
Safety	Underwriters Laboratories (UL) Listed per Subject Letter 1801: Power Distribution Center for Communications Equipment, and cUL Certified (CSA 22.2 950): Safety of Information Technology Equipment

---

## Cabinet Specifications

---

### Mechanical

---

Height	84.0 inches (2,134mm)
Width	23.6 inches (600mm)
Depth	23.6 inches (600mm)

---

### Thermal

---

12 Rectifiers	1,368W (4632 BTU/hr)
24 Rectifiers	2,736W (9264 BTU/hr)

---

### Environmental

---

Operating Temperature Range	0°C to +45°C (32°F to 113°F)
Operating Relative Humidity	< 95% non-condensing
Storage Temperature Range	-40°C to +85°C (-40°F to 185°F)
EMC	FCC and CISPR22 (EN55022) Class A
Immunity	GR1089, EN55024

---

### Agency Certifications

---

UL	Canada/US UL60950/UL1801
EMI/EMC	CISPR class B conducted and radiated

---

## Outline Drawing

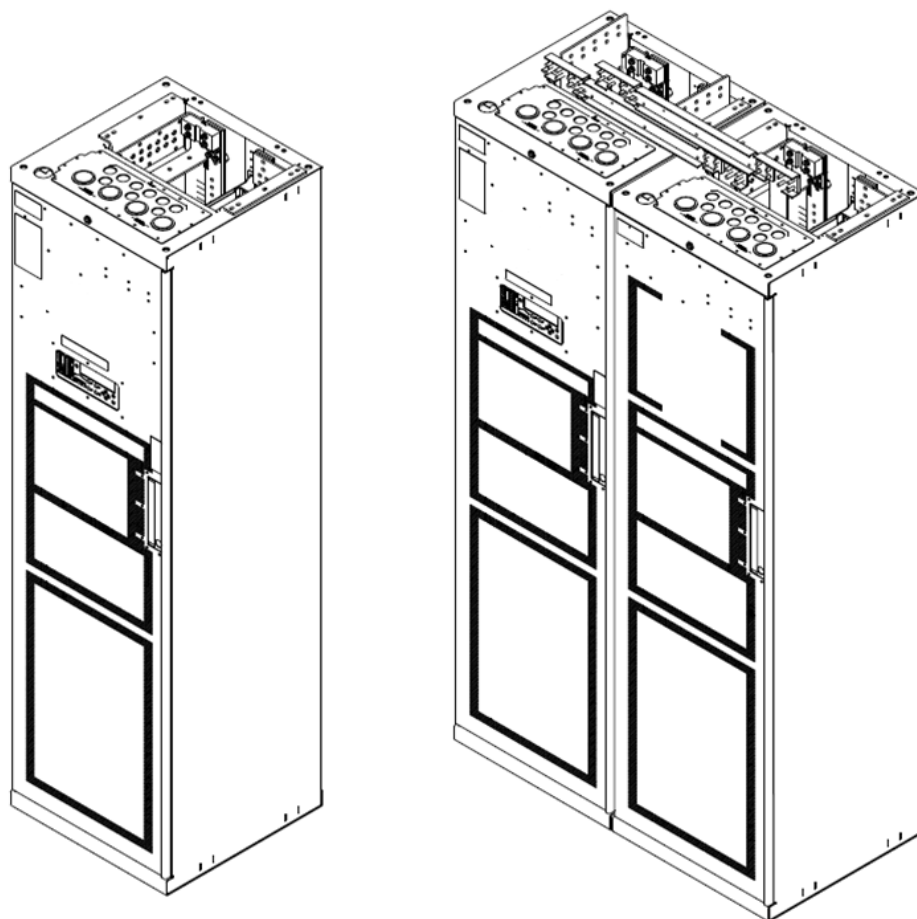

## AC INPUT SPECIFICATIONS

FOR	NAME PLATE RATING	EXTERNAL BREAKER		CONDUIT	WIRE SIZE (BASED ON WIRE RATED 75 C)	GROUND WIRE (BASED ON WIRE RATED 75 C)
		SIZE	QTY			
G021	1 AC FEED AT 130A, 200 VAC	150A	(1) 3 POLE	1 (2")	(3) 1/0 AWG	(1) 6 AWG
G022	2 AC FEED AT 130A, 200 VAC	150A	(2) 3 POLE	2 (2")	(6) 1/0 AWG	(2) 6 AWG
G026	12 AC FEED AT 15A EACH, 200 VAC	20A	(12) 2-POLE	1 (2")	(24) 8 AWG	(1) 8 AWG
	12 AC FEED AT 15A EACH, 200 VAC	20A	(12) 2-POLE	2 (1.5")	(24) 8 AWG	(2) 8 AWG
	12 AC FEED AT 15A EACH, 200 VAC	20A	(12) 2-POLE	4 (1")	(24) 10 AWG	(4) 10 AWG
	6 AC FEED AT 30A EACH, 200 VAC	40A	(6) 2-POLE	2 (1")	(12) 8 AWG	(2) 8 AWG
	24 AC FEED AT 15A EACH, 200 VAC	20A	(24) 2-POLE	2 (2")	(48) 8 AWG	(2) 8 AWG
G027	24 AC FEED AT 15A EACH, 200 VAC	20A	(24) 2-POLE	4 (1.5")	(48) 8 AWG	(4) 8 AWG
	24 AC FEED AT 15A EACH, 200 VAC	20A	(24) 2-POLE	8 (1")	(48) 10 AWG	(8) 10 AWG
	12 AC FEED AT 30A EACH, 200 VAC	40A	(12) 2-POLE	4 (1")	(24) 8 AWG	(4) 8 AWG
	8 AC FEED AT 45A EACH, 200 VAC	60A	(8) 2-POLE	2 (1.5")	(16) 4 AWG	(2) 6 AWG
	36 AC FEED AT 15A EACH, 200 VAC	20A	(36) 2-POLE	4 (1.5")	(72) 8 AWG	(4) 8 AWG
G028	36 AC FEED AT 15A EACH, 200 VAC	20A	(36) 2-POLE	3 (2")	(72) 8 AWG	(3) 8 AWG
	36 AC FEED AT 15A EACH, 200 VAC	20A	(36) 2-POLE	9 (1")	(72) 10 AWG	(9) 10 AWG
	18 AC FEED AT 30A EACH, 200 VAC	40A	(18) 2-POLE	3 (2")	(36) 4 AWG	(3) 6 AWG
	12 AC FEED AT 45A EACH, 200 VAC*	60A	(12) 2-POLE	4 (1.5")	(24) 4 AWG	(4) 6 AWG

\*Requires (8) CC408641204 AC Strapping Kits

---

## Ordering Information – GPS2436 Infinity Power System













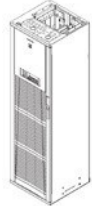

The GPS2436 system can be deployed with capacity of up to 2400 amps in a single cabinet or expanded over multiple cabinets to 3600 amps. Designed for either internal input AC breakers or terminal strip terminations, rectifier shelves can be spread across two bays or concentrated to a single bay. In applications needing additional distribution, two more bays can be added and dedicated exclusively for distribution.

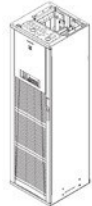
### Key Features

- Medium power applications utilizing single-phase or 3-phase 240Vac input
- Full featured control and monitoring capability
- 2400 Amp charge capacity per bay maximum
- Efficiency approaching 97%

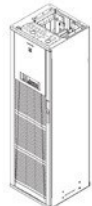
## Step 1: Select the Power Bays

Note: Even though all NE based rectifiers utilize single phase input, the GPS bays are designed to accept 3 phase input when the bulk feed (G021 or G022) is selected.

Output	Ordering Code	Model	AC Input	Picture
 1200A	150023168	GPS 2436 Primary Bay, Millennium II controller, bulk feed to Circuit Breakers 208-240V AC input for up to 12 NE100 rectifiers, battery shunt.	 PHS - PHS (1) 3PH AC Input 12 CircuitBreakers	  Vertical Distribution Available 60"
	H5692436G001, G011, G021			
 2400A	CC109167722	GPS 2436 Primary Bay, Millennium II controller, bulk feed to Circuit Breakers 208-240V AC input for up to 24 NE100 rectifiers, battery shunt.	 PHS - PHS (2) 3PH AC Inputs 12 CircuitBreakers	  Vertical Distribution Available 54"
	H5692436G001, G011, G022			
 1200A	150023169	GPS 2436 Primary Bay, Millennium II controller, terminal strip feed 208-240V AC input for up to 12 NE100 rectifiers, battery shunt.	 PHS - PHSor PHS - N 12 AC Feeds	  Vertical Distribution Available 60"
	H5692436G001, G011, G026			
 2400A	CC109167714	GPS 2436 Primary Bay, Millennium II controller, terminal strip feed 208-240V AC input for up to 24 NE100 rectifiers, battery shunt.	 PHS - PHSor PHS - N 24 AC Feeds	  Vertical Distribution Available 54"
	H5692436G001, G011, G027			

## Step 1: Select the Power Bays (continued)

Output	Ordering Code	Model	AC Input	Picture	
	150024271	GPS 2436 Primary Bay, Pulsar controller, Bulk feed to Circuit Breakers 208-240V AC input for up to 12 NE100 rectifiers, battery shunt.			
	150024270	GPS 2436 Primary Bay, Pulsar controller, Bulk feed to Circuit Breakers 208-240V AC input for up to 24 NE100 rectifiers, battery shunt.			
	150024272	GPS 2436 Primary Bay, Pulsar controller, terminal strip feed 208-240V AC input for up to 12 NE100 rectifiers, battery shunt.			
	150024269	GPS 2436 Primary Bay, Pulsar controller, terminal strip feed 208-240V AC input for up to 24 NE100 rectifiers, battery shunt.			





## Step 1: Select the Power Bays (continued)

Output	Ordering Code	Model	AC Input	Picture	
	150023173	GPS 2436 Secondary Bay, no controller, terminal strip feed 208- 240V AC input for up to 24 NE100 rectifiers, battery shunt. Use this bay with comcode 150023169 only. Requires External tie barkit, see step 8.			
	150023172	GPS 2436 Secondary Bay, no controller, terminal strip feed 208-240V AC input for up to 12 NE100 rectifiers, battery shunt. Requires External tie bar kit, see step 8.			
	150023171	GPS 2436 Secondary Bay, no controller, bulk feed to CircuitBreakers 208-240V AC input for up to 24 NE100 rectifiers, battery shunt. Use this bay with comcode 150023168 only. Requires External tie bar kit, see step 8.			
	150023170	GPS 2436 Secondary Bay, no controller, bulk feed to CircuitBreakers 208-240V AC input for up to 12 NE100 rectifiers, battery shunt. Requires External tie bar kit, see step 8.			
	150023174	GPS 2436 Centralized Architecture, Secondary Bay, distribution only. Vertical Distribution Space 72.0". No Controller. Can be used with any primary bay selected. Requires External tie bar kit, see step 8.			
		H5694827G002			Vertical Distribution Available 72"

### Additional Kits

Ordering Code	Model	2 Term Block Kits		3 Term Block Kits
CC408641204	Strapping kit to collect rectifier AC input on terminalblock. Options allow for 2 or 3 rectifiers per block.	12 Rectifiers	3	3
		24 Rectifiers	6	5
850019233	Bus Bar Extender: Used to terminate large battery terminations. Order one set per bay when required	Provides 16 return terminations		

## Step 2: Select Rectifiers

Output	Ordering Code	Description	Photo
	CC109160834	95-150Vac input, 24V, 45A output 175-275Vac input, 24V, 100A output	
100A	NE100AC24ATEZ		

## Step 3: Select Field Installed Distribution Panels

### North American Breaker Panels

Ordering Code	Group Code	Panel Description	Vertical Space(in.)	Internal Return Bars (Dist Arch Only)	GroupCode
108971474	G43A	6 Position 125A-800A Circuit Breaker Panel	12	108908070	G43
108971318	G42A	3 Position 125A-600A Circuit Breaker Panel	6	108908070	G42
108971417	G48B	5 Position 125A-800A Circuit Breaker Panel	9	108908070	G48
108971532	G96A	10 Position 3A-100A Bullet Breaker Panel	6	108908104	G96
108971680	G97A	14 Position 3A-200A Bullet Breaker Panel	6	108908104	G97
108987678	G98B	22 Position 3A-200A Bullet Breaker Panel	9	108908104	G98B

### North American Fuse Panels

108970872	G52A	10 Position 3A-60A TPS Fuse Panel	6	108908070	G52
108986746	G54A	5 Position 70A-225A TPL-B Fuse Panel	9	108908070	G54
CC109133113	G53A	2 Position 70A-600A TPL Fuse Panel	6	108908104	G53
108985235		6 position 1A-15A GMT Fuse Panel	0	NA	NA
108908070		Return Bus for panels in like shaded lines			
108908104		Return Bus for panels in like shades lines			





## Step 4: Select Distribution Components

Note: Plug in, and bolt in distribution components are listed below. These must be selected to match the distribution panels selected in Step 3.

### Bullet Style Load Circuit Breakers

Ordering #	Amperage	CB Positions (Poles)	Min Wire Gauge	Photo
407998137	3	1	10	
407998145	5	1	10	
407998152	10	1	10	
407998160	15	1	10	
407998178	16	1	10	
407998186	20	1	10	
407998194	25	1	10	
407998202	30	1	10	
408213486	40	1	8	
407998210	45	1	8	
407998228	50	1	6	
407998236	60	1	6	
407998244	70	1	2	
407998251	80	1	2	
407998269	90	1	2	
CC848808551	100	2	2	
408185353	125	2	2	
408185346	150	2	1/0	
408564941	200	3	2/0	
408535752	250	3	4/0	
848631479	2-pole adapter bus kit (includes bus for 1/4" hole lug on 5/8" centers and hardware), order one per breaker			
848745662	3-pole adapter bus kit (includes bus for 5/16" hole lug on 1" centers and hardware), order one per breaker			

## Step 4: Select Distribution Components (continued)

Large Circuit Breaker Kits				
Ordering #	Amperage	CB Positions (Poles)	Min Wire Gauge	Photo
108908187	125	1	2	
108908179	150	1	1/0	
108908195	175	1	2/0	
108908203	225	1	4/0	
108908211	300	2	2x4/0	
108908237	400	2	2x4/0	
108908229	500	3	3x4/0	
108908252	600	3	3x4/0	
108984782	800	4	4x4/0	

Large TPL Fuses				
Ordering #	Amperage	Max#wires per position	Min Wire Gauge	Photo
408472322	70-250A Fuse Holder Head			
402328926	0.18A Alarm Fuse			
406794776	70	3	6	
408239648	80	3	4	
406794784	100	3	2	
406925685	125	3	2	
406794792	150	3	1/0	
406794818	200	3	4/0	
406794982	225	3	4/0	
406794842	250	3	4/0	
406794867	300	3	2x4/0	
406794875	400	3	2x4/0	
406794883	500	3	2x4/0	
406794891	600	3	3x4/0	

## Step 4: Select Distribution Components (continued)

### Bullet Style Fuse Holder and TPS Fuses

Ordering #	Amperage	WP-92461 List	Min Wire Gauge	Photo
406700567	3	100	10	
406700583	5	101	10	
406700591	6	102	10	
406700609	10	103	10	
406700617	15	104	10	
406700625	20	105	10	
406700633	25	106	10	
406700641	30	107	10	
406700658	40	108	10	
406700674	50	109	8	
406700682	60	110	6	
406700690	70	111	6	
402328926		0.18 Alarm Fuse		

408548944 Bullet Fuse Holder, TFD-101-011-09 (Alarms on Blown Fuse or Fuse Head Removal)



CC408617410 Bullet Fuse Holder, TFD-101-011-10 (Alarms on Blown Fuse Only)

### GMT Fuses

405006222	0.25A	
406976894	0.5A	
405673146	1.33A	
405181983	2A	
406976985	3A	
406159061	5A	
405725433	7.5A	
406159236	10A	
407845197	12A	
406473959	15A	
408515823	Fuse Puller	







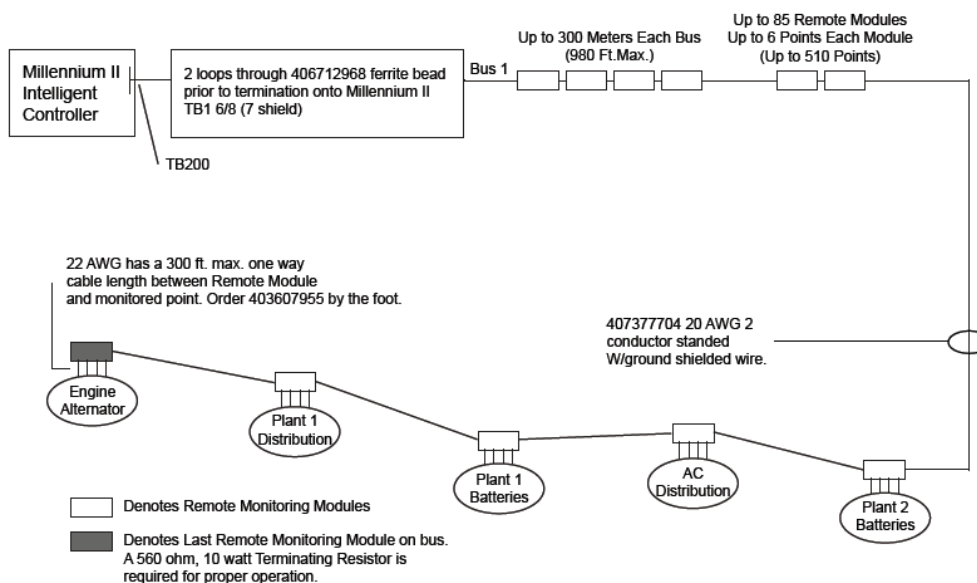

## Step 5: Select Remote Peripheral Monitoring Options

Ordering #	Description	Photo
	<b>Modules</b>	
	<b># Inputs</b>	<b># Temp</b>
108469461	J85501G1L21 RPM Shunt Monitoring (221F)	6 1
108469479	J85501G1L22 RPM Voltage 0-200VDC (221D)	6 1
108469495	J85501G1L23 RPM Transducers (221J)	6 1
108298431	J85501G1L24 RPM Voltage 0-3VDC (221A)	6 1
108298498	J85501G1L25 RPM Voltage 0-16VDC (221B)	6 1
108469503	J85501G1L26 RPM Voltage 0-70VDC (221C)	6 1
108298449	J85501G1L27 RPM Binary (222A)	6 1
108483538	J85501G1L28 RPM Temperature (223T)	0 7
108298456	J85501G1L9 RPM Control Relay (214A)	3 0
	<b>Supporting Material</b>	
407377704	Connecting Cable for RPMs (Order by foot)	
848535332	Blue panel for mounting 6 modules above a GPS cabinet	
848412367	White panel for mounting 6 modules in a 23-inch frame inside GPS bay	
847307410	12' Cable to be used with Temperature Probes	
847917879	1/2" Diameter Ring Terminal Temperature Probe (Cable Required)	
848528881	5/16" Diameter Ring Terminal Temperature Probe (Cable Required)	
405298308	Termination Resistor (1 per bus)	
406712968	Ferrite Bead (1 per bus)	
403607955	Monitor Channel cable KS13385 22AWG stranded pair, R&Bk (order by the foot)	
108984477	23" grey panel, 6 RPM mounting panel for Lorain plants	

### Millennium Remote Monitoring



## Step 6: Select Optional AC Monitoring Equipment (Millennium 2 Controller only)

AC Monitoring Options		
Ordering #	Description	Photo
<b>Configured Panels</b>		
CC408646005	3P/3W 208/240V Line to Line, 10x12x14 box provides current, voltage, and power	
CC408646046	3P/3W 480V Line to Line, 10x12x14 box provides current, voltage, and power	
CC408646054	3P/4W 208V Line to Neutral, 10x12x14 box provides current, voltage, and power	
<b>Transducers</b>		
CC408645808	1-phase AC Current Transducer (Built-in CT; 150A max current; 350 kcmil maxconductor size)	
CC408645816	1-phase AC Voltage Transducer 120V	
CC408645824	1-phase AC Voltage Transducer 208/240V	
CC408644537	3-phase AC Voltage Transducer 208/240V Line to Line	
CC408645741	3-phase AC Voltage Transducer 208/240V Line to Neutral (120V)	
CC408645832	3-phase AC Voltage Transducer 480V Line to Line	
CC408645840	3-phase AC Current Transducer	
<b>Current Transformers (Required for configured panels and current transducers)</b>		
CC408645857	Current Transformer, 200A primary, 5A secondary, 4 in inside diameter	
408524862	Current Transformer, 400A primary, 5A secondary, 4 in inside diameter	
CC408645865	Current Transformer, 600A primary, 5A secondary, 6 in inside diameter	
CC408645873	Current Transformer, 800A primary, 5A secondary, 6 in inside diameter	
CC408645881	Current Transformer, 1000A primary, 5A secondary, 8 in inside diameter	
CC408645898	Current Transformer, 1200A primary, 5A secondary, 8 in inside diameter	
<b>Miscellaneous</b>		
CC408645907	Barrier terminal block to extend the CT secondary leads beyond their 12 ft factory length. Use 12 AWG THHN wire in conduit.	
CC408645915	Bud Industries Wall Box (12H x 10W x 8D) w/captive screw cover & internal mounting panel. For mounting transducers	

## Step 7: Select Battery Termination Options

Order optional termination bar if standard 8 positions may be exceeded

Ordering #	Description
850019233	Optional bus bar that provides 16 output terminations. (one required per cabinet)
848385878	Optional adapter that allows two lugs to be stacked and connected at one location. (Provides one adapter)

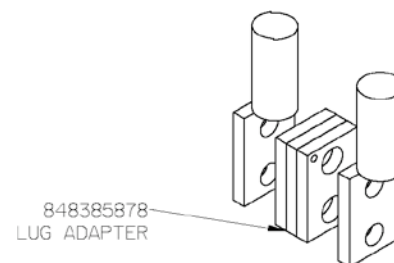
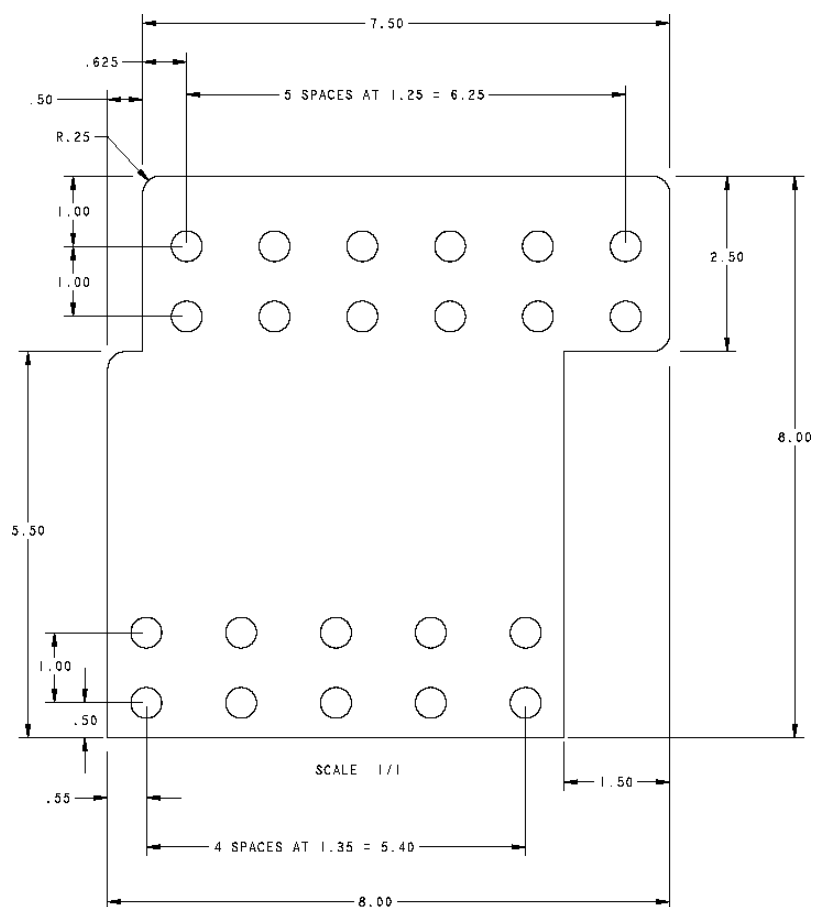



## Step 8: Select Optional Return Bus Bars

### Standard Architecture 600mm Bays

Ordering #	Description
CC848805160	External Return Bus Kit: Option for termination of all distribution return cables. 1 per cabinet, rated at 1800 Amps. The external return bus kit is an alternative to internal return buses when many large cables are required.
150023060	External Tie Bar Kit: Used when adding supplemental bay(s). 1 per cabinet, rated at 1800 Amps. Used with system not exceeding 12 total rectifier shelves.
150022833	External Tie Bar Kit: Used when adding supplemental bay(s). 1 per cabinet, rated at 5000 Amps. Used with systems equipped with 13-24 total rectifier shelves.

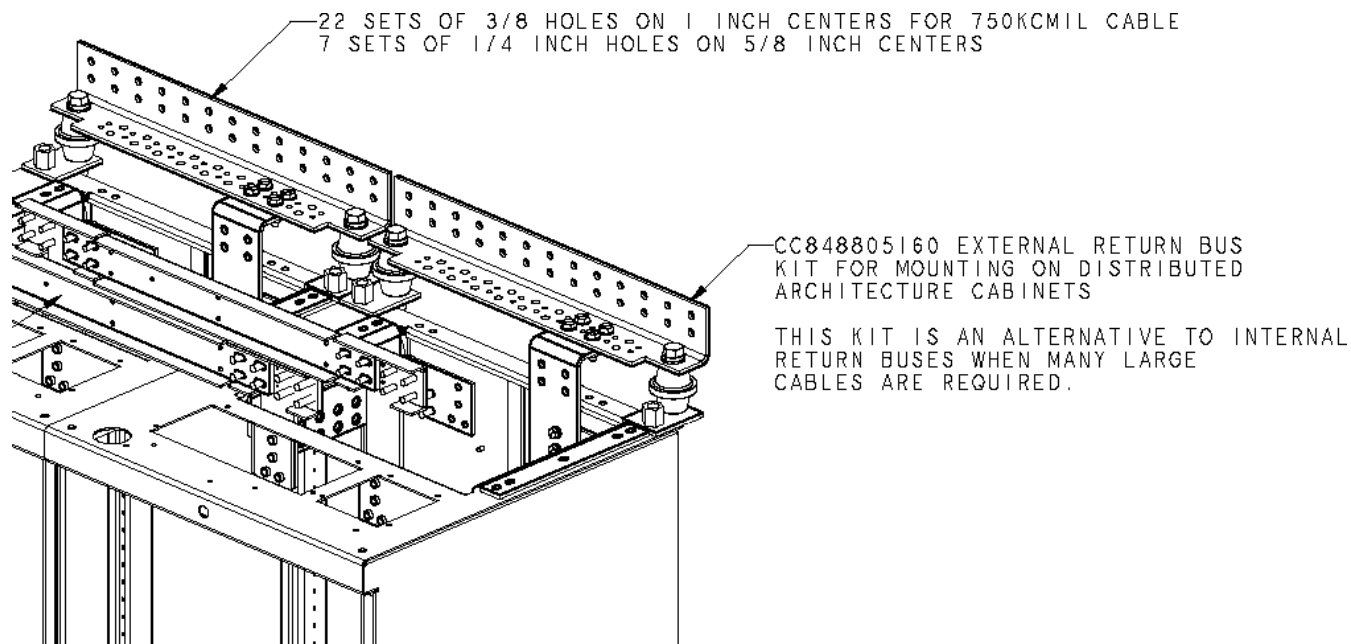

—  
Notes:

---

## Management Visibility

Galaxy Manager™ software is the centralized visibility and control component of a comprehensive power management system designed to meet engineering, operations and maintenance needs. The Galaxy Manager client-server architecture enables remote access to system controllers across the power network.

- Dashboard display with one-click access to management information database
- Trend analysis
- Scheduled or on demand reports
- Fault, configuration, asset, and performance management

## Training

ABB Energy offers on-site and classroom training options based on certification curriculum. Technical training can be tailored to individual customer needs. Training enables customers and partners to more effectively manage and support the power infrastructure. We have built our training program on practical learning objectives that are relevant to specific technologies or infrastructure design objectives.

## Service & Support

ABB Energy field service and support personnel are trusted advisors to our customers – always available to answer questions and help with any project, large or small. Our certified professional services team consists of experts in every aspect of power conversion with the resources and experience to handle large turnkey projects along with custom approaches to complex challenges. Proven systems engineering and installation best practices are designed to safely deliver results that exceed our customers' expectations.

## Warranty

ABB Energy is committed to providing quality products and solutions. We have developed a comprehensive warranty that protects you and provides a simple way to get your products repaired or replaced as soon as possible.

For full warranty terms and conditions please go to [abbpowerconversion.com](http://abbpowerconversion.com)



---

**ABB**

601 Shiloh Rd.  
Plano, TX USA

[abbpowerconversion.com](http://abbpowerconversion.com)

We reserve the right to make technical changes or modify the contents of this document without prior notice. With regard to purchase orders, the agreed particulars shall prevail. ABB does not accept any responsibility whatsoever for potential errors or possible lack of information in this document.

D0000030490

Page 28

© 202 ABB. All rights reserved.

We reserve all rights in this document and in the subject matter and illustrations contained therein. Any reproduction, disclosure to third parties or utilization of its contents – in whole or in parts – is forbidden without prior written consent of ABB.

Copyright© 2021 ABB  
All rights reserved

GPS2436\_OG

Rev. 1.3