

IBB-250WM Battery Charger System

The IBB-250 WM is an industrial power system designed to deliver significantly more power than conventional battery chargers in wall- or rack-mounted applications. Compliant with industry standards (including NEMA PE-5), the IBB-250WM's reliability, modularity and advanced controller capabilities provide an infrastructure not just for today, but for years to come.



IBB-250WM Battery Charger System

Doc 2131153 Issue 3.1

PRODUCT DESCRIPTION

HIGHEST RELIABILITY

Reliability is a cornerstone of industrial applications, and it is a critical requirement for the DC power systems that support them. The IBB-250 WM offers:

- Modular architecture enabling affordable (N+1) redundancy
- MTBF of each rectifier module >350,000 hours
- An individual module failure has no impact on load in N+1 System
- Replacing a failed unit is no longer a fire drill
 - Spare modules are practical to stock
 - Hot plug-in design
 - No disruption to a working system

KEY FEATURES

- 6 FORM 'C' CONTACT RELAYS RATED AT 75 VDC
- 3 FORM 'C' CONTACT RELAYS RATED AT 125 VDC STANDARD ON 125V CHARGERS
- COMMUNICATIONS: MODBUS, TCP/IP
- REVERSE BATTERY POLARITY PROTECTION
- SURGE PROTECTION DEVICE
- BATTERY ELIMINATOR FEATURE

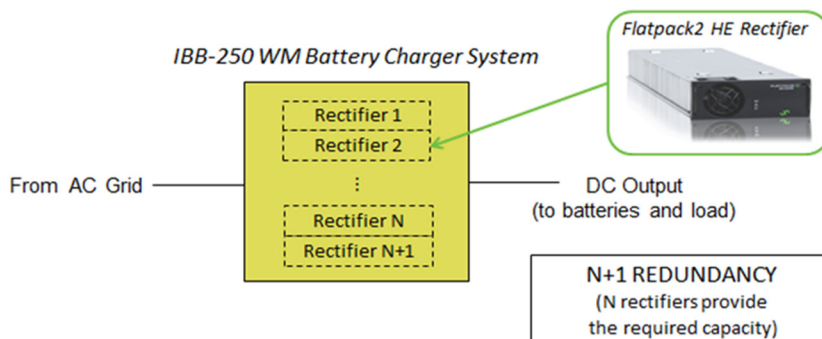

IBB-250WM Battery Charger

Doc 2131153 – rev3.1



SYSTEM CONFIGURATIONS

Product Family	DC Output		Single Phase (50HZ or 60HZ)			Three Phase (50HZ or 60HZ)		
	Voltage (Nominal)	Capacity (Amps)	Input Voltage	Current (Max)	Base P/N	Input Voltage	Current (Max)	Base P/N
IBB-250 WM	125V	80A	120/208/240 VAC	75A	310118			
			120/208/240 VAC	75A	334232 (Beige)			
	125V	80A				208/240 VAC	75A	328392 (Beige)

CONTROLLER AND COMMUNICATIONS

Controller Model	Smartpack2 Touch with the Basic Industrial Controller, and I/O Monitor 2
SCADA Gateway	None, DNP3
Visual Alarming	Major, Minor, Power On, LCD Display
Remote or Local Monitoring and Control	Ethernet via web browser RS232/RS485
Industrial Protocols	SNMP V1/V2c and V3, ModBus, ModBus TCP
Inputs/Outputs	6 each, programmable, contacts rated for 1 Amp at 75 Volts (I/O Monitor 2) 3 contacts rated at 0.2A at 125 VDC (Industrial Basic Controller)
Data Logging	Up to 10,000 events
Battery Management	Auto monitoring/testing life/capacity indications (requires battery connection system listed in options)
Ground Fault Detection	Interface via controller

INPUT / OUTPUT FEATURES

AC and DC Breakers	UL Listed, Front Accessible
AC Surge Protector	UL Recognized, 8/20 μ s, 40 kA
Voltage Regulation	\pm 0.5% from 10% to 100% load
THD	<5% at Nominal Input and Full Load
Power Factor	Greater than 0.99 @ 50% load or more
Ripple and Noise	125V: 50mVRMS (with battery) 100 mVRMS (without battery) (Battery eliminator standard)
Reverse Polarity Protection	Built-in Diode

ENVIRONMENTAL

Operating Temperature	-40 to +50°C (-40 to 122°F), de-rates from 50 to 65°C†
Storage Temperature	-40 to +70°C (-40 to 158°F)
Cooling	Fan cooled rectifiers (front to back)
Operating Humidity	5 to 95% RH non-condensing
Storage Humidity	0 to 99% RH non-condensing

APPLICABLE STANDARDS

	MODULES	IBB-250WM
Electrical safety	IEC60950-1/UL60950-1/ CSA C22.2,	UL1012, CSA C22.2 listed
EMC	EN 61000-6-1,2,3,4	N/A
Mains Harmonics	EN 61000-3-2, 3-4	N/A
Environment	2002/95/EC (RoHS), 2002/96/EC (WEEE)	N/A
NEMA Standard	N/A	PE-5-1997
Surge	N/A	IEEE 1613/ANSI/IEEE C37.90.1

FLATPACK2 MODULES

Part No.	Description	Operating Output Range	Battery Support (Max # of Cells)		Typical Efficiency
			Lead Acid	Nickel Cadmium	
241119.805	110-125V /20A HE	90.0 – 151.25V	60	91 Cells	94.5%

IBB-250WM Battery Charger

Doc 2131153 – rev3.1



ADDITIONAL TECHNICAL FEATURES

Cost-Saving Efficiency

The IBB-250 WM's efficiency performance far exceeds the industry standard, reducing power usage and lowering operational costs.

- Utilizes Flatpack2 HE rectifiers typically operating at efficiencies > 94% (see rectifier specs)
- Flatpack2 HE rectifiers reduce wasted power by more than 50% versus the typical SCR battery chargers used today (see example below).

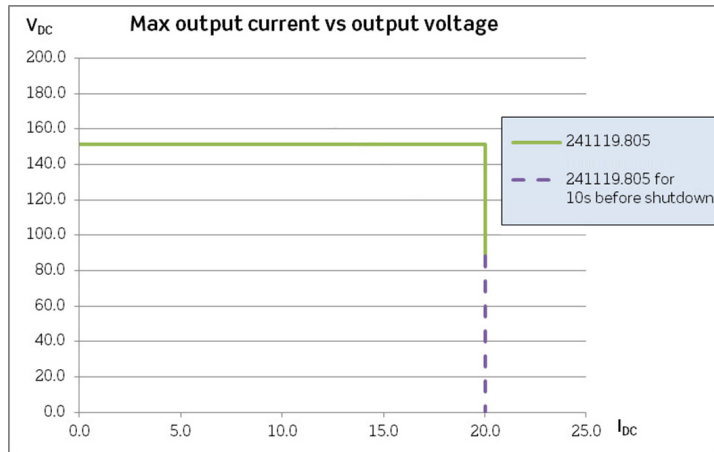

125V/20A Rectifier

Advanced Monitoring/Control

IBB-250 WM systems include the state-of-the-art Smartpack2 Touch controller, which capably:

- Provides comprehensive system monitoring, reporting, and diagnostics in an intuitive, easy to use format
- Stores up to 10,000 events or data entries in its logs
- Performs extensive battery management
- Thermal compensation charging
- Automated battery monitoring and testing
- Capacity and lifetime indicators
- Enables local or remote monitoring and control via Ethernet (web browser)
- Supports SNMP protocol with TRAP, SET and GET on Ethernet, including e-mail of TRAP alarms
- Provides SCADA interfaces including MODBUS over TCP, DNP3
- Supports floating systems with ground fault detection



Smartpack2 Touch Controller

COMPARISON: IBB-250 WM VERSUS TYPICAL SCR BATTERY CHARGER

125V System	IBB-250 WM	Typical SCR Battery Chargers	
Capacity	80A	30A	75A
Height	22.6 in	26.8 in	38.0 in
Width	16.8 in	17.9 in	20.9 in
Depth	18.0 in	16.0 in	16.8 in
Weight ¹	125 lbs	n/a	n/a
Weight ²	151 lbs	200 lbs	420 lbs
Wall Mount	Yes	Yes	Sometimes
Rack Mount	Yes	Yes	No

1 Weight shown without rectifiers

2 Weight shown with maximum # of rectifiers; each rectifier weighs 4.3 pounds.

IBB-250WM Battery Charger

Doc 2131153 – rev3.1



ORDERABLE PART NUMBER

310118 . 00 . 000
1 2 3

- 1) Six-digit base part number
(see "System Configurations" on page 2)
- 2) SCADA Protocol
00 – None
02 – DNP3
- 3) Controller Profile
Default is 000. For custom profile numbers, contact sales.

OPTIONS

- Temperature compensation probe(s)
(contact sales for additional options)
10 ft. cable with ¼" lug (340403)
20 ft. cable with ¼" lug (340521)
- IBB-250WM Battery Connection System
Required for controller battery management
(Part No. 319672)
- Drip Shield (Part No. 309348)
- SCADA Gateway Field Install Kit
DNP3 (Part No. 321642)
- Optional breaker sizes available (call sales)
- Additional Form C Relays
FlexiMonitor (Part No. 242100.603)
4 Relay Kit (Part No. 242100.605)
8 Relay Kit (Part No. 242100.604)
- Replacement Breakers for Legacy Systems
80A retrofit kit (Part No. 3798102354)
100A retrofit kit (Part No. 3798102355)

