

# BATTERY ROLLER CHARGER STAND



**Safe and economic means of charging and storing forklift batteries.**

Sackett Systems Battery Roller Charger Stands provide a safe and economical means of charging and storing forklift batteries. Ruggedly built with a fully welded frame of heavy duty steel construction in two, three, four, six and eight compartments customized to meet customer needs. The rollers are made with non-conductive material with precision sealed bearings for long lasting.

Stands are finished in acid resistant paint customized with drip pans, adjustable legs, and battery safety stops. This durable construction allows for both opportunity charging or conventional charging forklift fleets. Stands are available in a full range of depths, widths and transfer heights. Sackett can help design the ideal cost savings, efficient stand for every forklift fleet size and battery sizes.

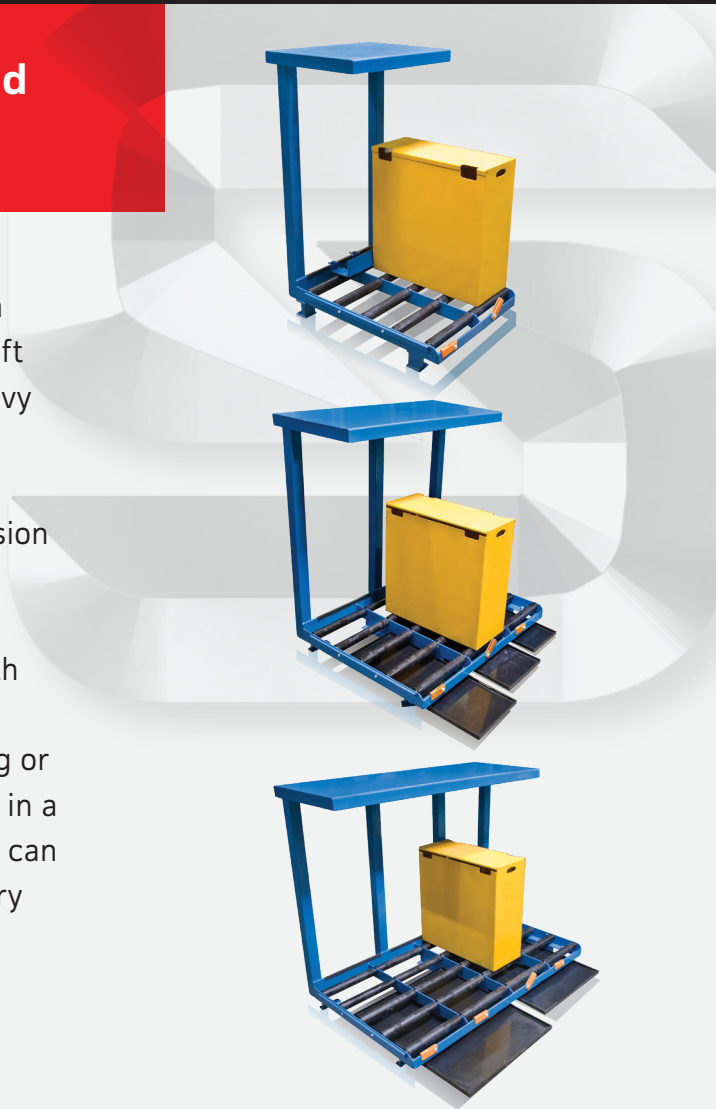

## FEATURES

- Configured range of single, double, triple and quad stands to support all battery dimensions and transfer heights
- Fully welded design finished for long lasting, durable construction
- Acid resistant paint prevents corrosion & mitigates staining
- 40" roller bed is standard
- 50" clearance is standard
- Charger platform 25" deep (800 lb capacity) is standard
- Upright size is 3" x 3" x 1/4"
- 23/2" diameter rollers with all steel bearings handle even the heaviest workload.
- Non-conductive and non-slip roller covers with 11/16" hex axle
- Simple to adjust legs to allow compensation for uneven floors
- Standard flip up stops to ensure safe changes of batteries
- Standard color - Visual Blue
- Adjustable legs with 1" threaded rod

# BATTERY ROLLER CHARGER STAND

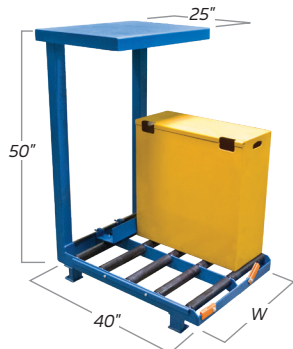

**2 COMPARTMENT STAND**

MODEL	ROLLER WIDTH	WIDTH
CS12-2	12"	26-1/2"
CS15-2	15-1/4"	33"
CS18-2	18"	38-1/2"
CS21-2	21"	44-1/2"
CS24-2	24"	50-1/2"
CS27-2	27"	56-1/2"
CS30-2	30"	62-1/2"
CS33-2	33"	68-1/2"
CS36-2	36"	74-1/2"

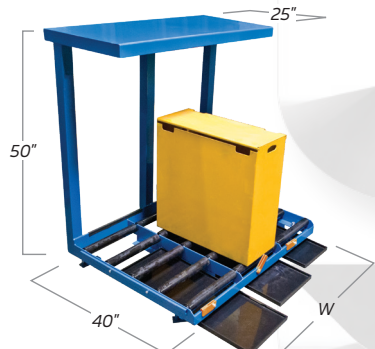

**3 COMPARTMENT STAND**

MODEL	ROLLER WIDTH	WIDTH
CS12-3	12"	38-3/4"
CS15-3	15-1/4"	48-3/4"
CS18-3	18"	56-3/4"
CS21-3	21"	65-3/4"
CS24-3	24"	74-3/4"
CS27-3	27"	83-3/4"
CS30-3	30"	92-3/4"
CS33-3	33"	101-3/4"
CS36-3	36"	110-3/4"

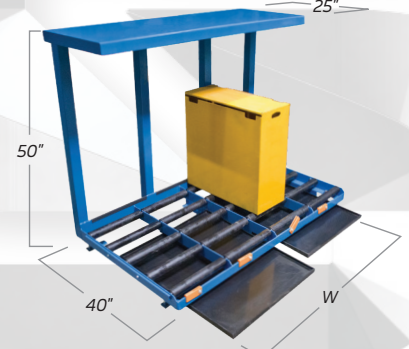

**4 COMPARTMENT STAND**

MODEL	ROLLER WIDTH	WIDTH
CS12-4	12"	51"
CS15-4	15-1/4"	64"
CS18-4	18"	75"
CS21-4	21"	87"
CS24-4	24"	99"
CS27-4	27"	111"
CS30-4	30"	123"
CS33-4	33"	135"
CS36-4	36"	147"

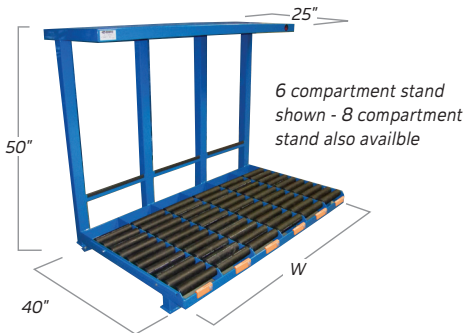

**6 & 8 COMPARTMENT STAND**

MODEL	ROLLER WIDTH	WIDTH
CS12-6	12"	75-1/2"
CS15-6	15-1/4"	95"
CS18-6	18"	111-1/2"
CS21-6	21"	129-1/2"
CS12-8	12"	100"
CS15-8	15-1/4"	123"
CS18-8	18"	147"



**LCP STAND**

 <b>BACK STOPS</b>	 <b>DRIP PAN KIT</b>	<p><b>Sackett's Roller</b>   <b>Competitor's Roller</b></p> <p>Steel Roller with 1/4" Thick Polyethylene Outer and Precision Sealed Bearings Outperforms the Competition</p>
 <b>STANDARD FLIP-UP STOPS</b>	 <b>HIGH LEG KIT</b>	
<b>HEAVY-DUTY ROLLERS</b>		

## OPTIONS

- 45", 50" roller bed
- Custom widths and compartment sizes
- Drip pan brackets
- Fully welded charger shelf
- Polypropylene drip pans contains battery fluid overflows and easy, removable clean-up
- Cable retractor mounting holes
- Customized battery back stops for smaller batteries
- Slide strips
- Cable management systems
- Less Charger Platform (LCP)
- High Leg Kit with range 9"– 27-1/4"

FEATURES	DIMENSIONS
Roller bed	40" deep
R-Dimension*	5-1/4" – 19-1/4"
R-Dimension adjustability	1-1/2"
Battery clearance	50"
Charger platform	25" deep, 800lb cap.
Upright size	3" x 3" x 1/8"
Legs	1" threaded rod
Roller axle	11/16" hex

\* With Leg Kit