

POWERED TRAVELING A-FRAME



POWERED TRAVELING "A" FRAME

Our Powered Traveling "A" Frame eliminates the high cost of a Bridge Crane or a Jib Crane. Track mounted Hydraulic Powered wheels assure smooth travel. With controlled speed, batteries are easily and safely transferred from vehicle to a designated battery station. Built for continuous use, this rugged "A" frame will give you years of safe, reliable services.

NEMA I enclosures
Primed & Painted finish
Variable travel speed

SPECIFICATIONS:

- Two and Three ton Capacity
- Up to 20 ft. span between uprights
- 10 ft. under beam standard
- Hydraulic powered forward/reverse travel
- Dual wheel drive
- Variable travel speed
- Double flange casters 10" dia.
- 2 H.P. Power Unit
- 240/480v-3 PH TEFC

OPTIONS:

- 12 ft. under beam available
- Wider spans available
- Variety of Guide Systems
- Higher lifting capacities
- Manual or Powered Trolley



SACKETT
Lifting, Stacking, Storing
INNOVATING SINCE 1897

1033 Bryn Mawr Ave. • Bensenville • IL • 60106 • USA
630.766.5500 • fax 630.766.5631 • www.sackettsystems.com

POWERED TRAVELING A-FRAME

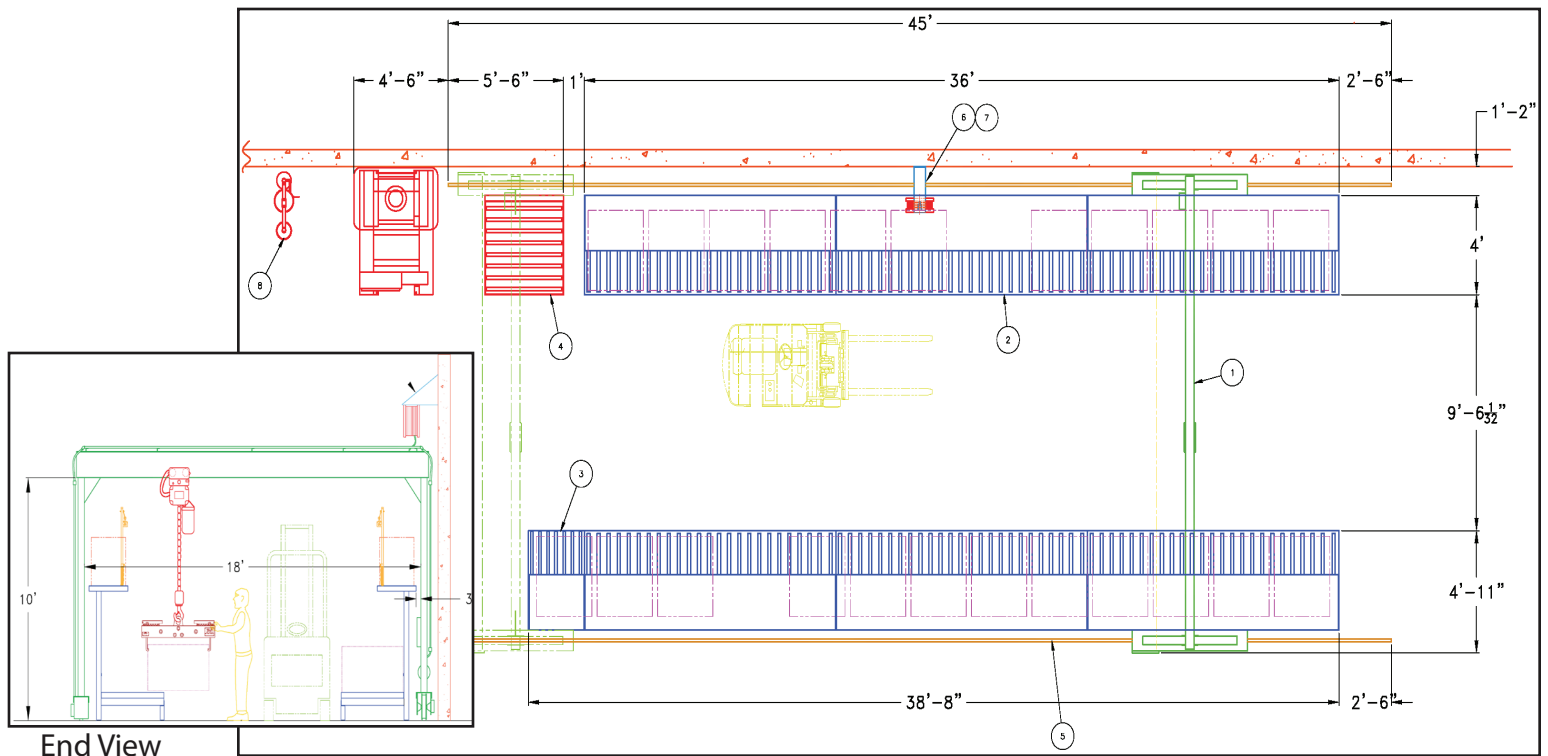

OVERHEAD BATTERY EXTRACTION



HARDWOOD CHARGING STANDS

Model	W
CS30-W	32"
CS42-W	44"
CS60-W	62"
CS72-W	74"
CS84-W	86"
CS100-W	100"
CS120-W	120"

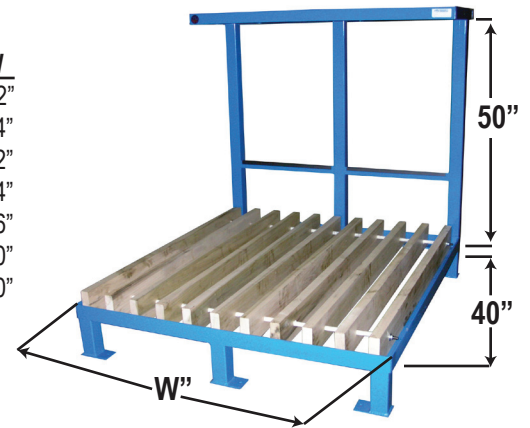

BATTERY LIFTING BEAMS

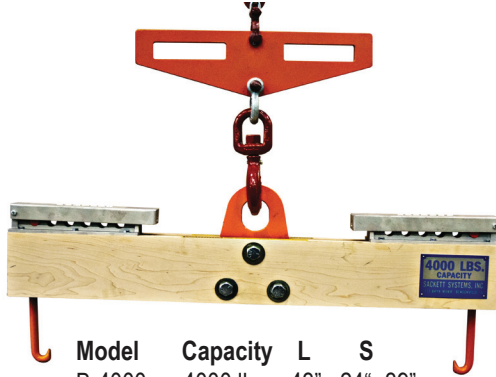

Model	Capacity	L	S
B-4000	4000 lbs.	43"	24" - 39"
B-6000	6000 lbs.	47"	28" - 43"

BATTERY WASH RACK

Model WR-1

Wood Wash Rack
W = 45" B = 48"

Model WR-1R

Roller Wash Rack
W = 45" B = 51 1/2"

OPTIONS

- Drain Tray
- Splash Sides

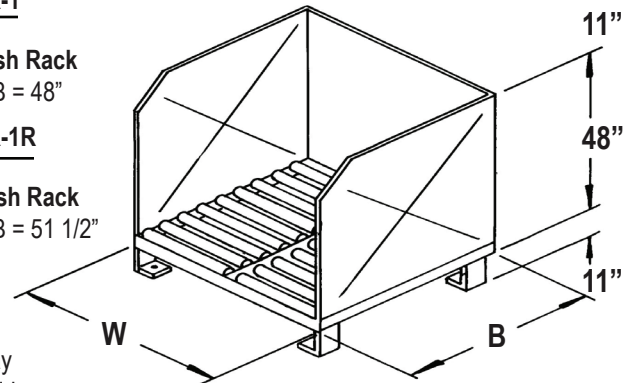

SACKETT
Lifting, Stacking, Storing
INNOVATING SINCE 1897

1033 Bryn Mawr Ave. • Bensenville • IL • 60106 • 800.323.8332
630.766.5500 • fax 630.766.5631 • www.sackett-systems.com