

PALLET JACK TRANSFER CARTS

→ 4,000 LB CAPACITY



**Safe and affordable pallet jack transportation
of forklift batteries.**

Whether you are utilizing opportunity charging, or conventional charging, these durable carts allow batteries to be removed quickly from forklifts for charging, servicing or watering. Available in several models and widths, Sackett has transfer cart solutions that save you time – and money, while keeping your business moving.

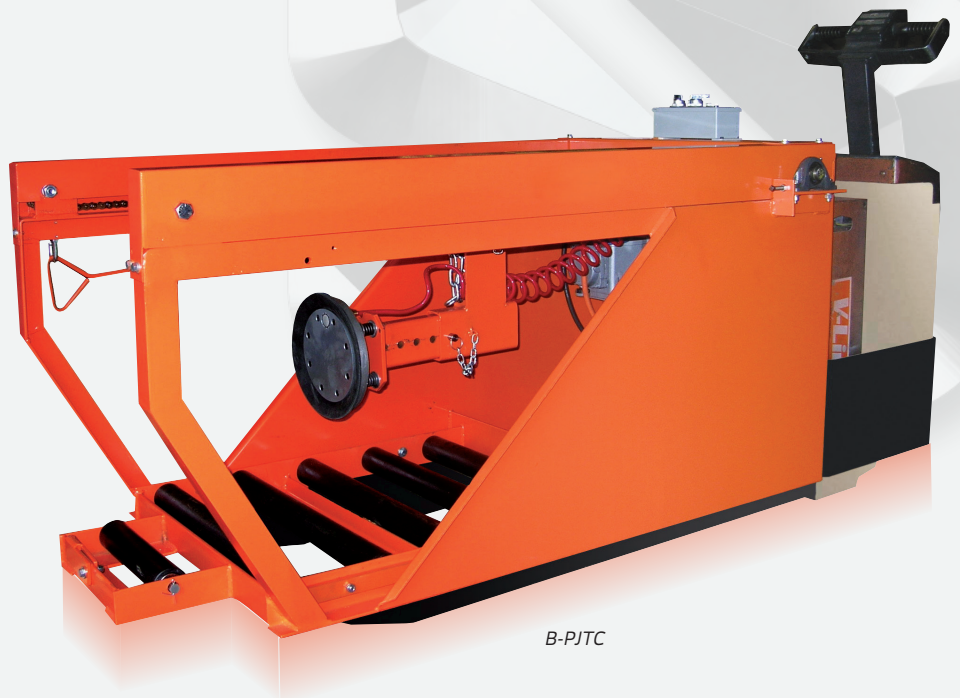

Model A-PJTC is the most economic alternative which allows manual battery extraction from fork lift and can be pushed into a fork lift manually. This model utilizes the pallet jack or fork lift to move the transfer cart. Ideal usage: 1-5 battery changes per day.

Model B-PJTC is the safest and the best value – it has powered extraction of the battery from the forklift and uses the powered extraction arm to push the battery back into the forklift. Ideal usage: 5-20 battery changes per day.

Model C-PJTC is the most versatile – it is powered like the B-PJTC but has a range of transfer heights from 6-1/2" to 26-1/2". Ideal usage: 5-20 battery changes per day.

PALLET JACK TRANSFER CARTS - 4,000 LB CAPACITY

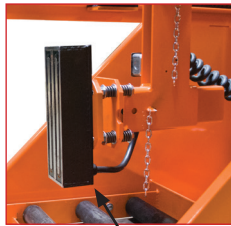

Magnet Or Vacuum
Extraction Available

Control Box Magnet/
Vacuum Indicator Light

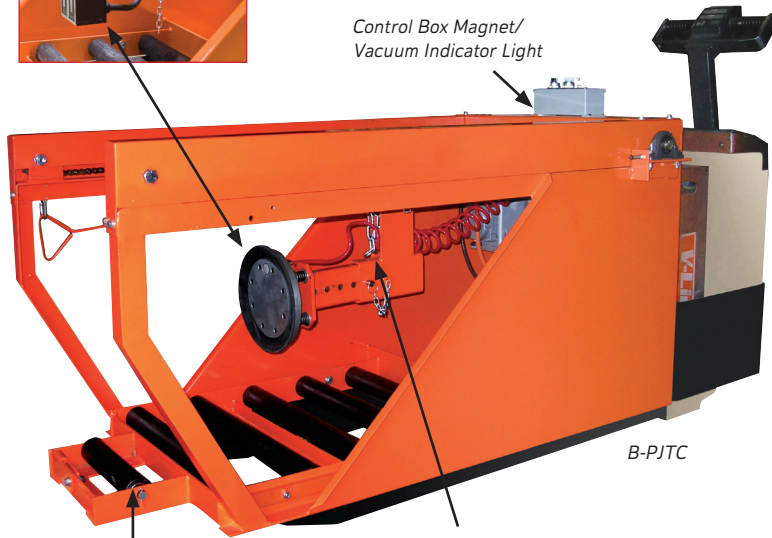

B-PJTC

Roller Bed
Designed For Use
With Outriggers

Safety Chain



Pictured With
A Drive Under
Base Option

A-PJTC-24



C-PJTC

MODELS AVAILABLE

A-PJTC:

Manual Extraction

Lift: Utilize lift of Pallet Jack

Roller Height: 6-1/4" to 12-1/4"

Reliable standard manual extraction

B-PJTC:

Hydraulic or Electric Powered Extraction

Lift: Utilize lift of Pallet Jack

Roller Height: 6-1/4" to 12-1/4"

Safest, most economical,
powered extraction

C-PJTC:

Hydraulic Powered Extraction

Lift: Independent Hydraulic
Powered Lift

Roller Height: 6-1/2" to 26-1/2"

Offers maximum range for fleets with
different battery transfer heights

FEATURES (ALL MODELS)

- 4,000 lb. Capacity
- 24", 30" and 36" Wide
Compartment Available
- 40" Deep Roller Bed
- 2-3/8" Dia. Non-Conductive Rollers
- 48" Fork Length Required
- Safety Hook and Chain

FEATURES (MODELS B-PJTC & C-PJTC)

- Magnet or Vacuum Extraction for
the same price (see picture)
- Magnet/Vacuum Indicator Light
- Adjustable Telescoping Extractor
Arm (4" - 8.5")
- 24v Solenoid Controls
- Y-Connector to Simultaneously
Power Pallet Jack and Transfer Cart

OPTIONS (ALL MODELS)

- 45" Deep Roller Bed - (54"
Forks Required)
- Drive Under Base - does not require
dedicated pallet truck (raises roller
height 1/2")
- 90° Fork Lift Truck Pocket
- 36v Controls
- Push & Pull Plate (no magnet/vacuum)
- High "R" Spacer to Achieve Higher than
12-1/4" Roller Height (model A & B only)
- Removable insert (roller or slide strip for
wider range of transfer heights)
- Clamp on kit (A-PJTC & B-PJTC)
- Welded to pallet jack
- Pallet Jack or Fork Lift not included

CONTACT US TO LEARN MORE

sales@sackettssystems.com or 800.323.8332

©2021 SACKETT SYSTEMS

V21.08.01