

10-322

For utility and telecommunications applications

- Microprocessor Controlled
- 24, 48 and 130-Volt Models
- 6 to 50 Amperes Output
- High Efficiency and Power Factor
- Single-Phase, Controlled Ferroresonant
- Digital Controls
- Low Electrical Noise
- Inherently Safe Design
- Low Maintenance
- Temperature Compensation
- Utility Switchgear
- Off Shore
- Pipe Line
- Telecommunication



FIVE YEAR WARRANTY



www.unipowerco.com

North America & CALA: +1 954-346-2442 • EMEA: +1 561-990-3830 • sales@unipowerco.com

Micro ARE Series FLOAT RECTIFIERS

Controlled ferroresonant float rectifiers have many inherent advantages...voltage regulation, short circuit protection, low operating costs (a combination of high efficiency and low power factor), easy maintenance and high reliability.

The Micro ARE Series of float rectifiers combines these inherent advantages with advanced rectifier, control and filter circuitry, and user-friendly operator interface. Designed specifically for utility and communication applications, the Micro ARE Series rectifiers are easily adjusted to meet your specific operating requirements and will provide years of low maintenance service.

INPUT

Transformers are dual wound for either 120, 208, 240 volts (+10%, -12%) or for 480 volts, single phase, (60 Hz +/- 3Hz). ARE-M13050 is wound for 208, 240, and 480 volts.

REGULATION

DC voltage is maintained within +/-0.5 % at any load from no load to full load with +10%,-12% variation (or ANSI standard ranges) in the AC input voltage while floating rated number of cells.

Control is accomplished with a single microprocessor-control board and can operate with or without a battery.

During operation, the maximum output voltage transient does not exceed 6% of the initial steady-state voltage for sudden load changes between 10% and 90% of rated output. Recovery takes less than 300 milliseconds. Operation without a battery is stable under all conditions of line and load (within stated limits).

Turn-on under all conditions of line and load has a "soft-start" characteristic without overshoot.

ELECTRICAL NOISE

For 24 and 48-volt models, the filtering provided produces a ripple level of less than 30 millivolts rms with electrical noise less than 22 dBrc measured on a battery with an eight-hour capacity rating of four times the rectifier current rating.

For 130-volt models, the filtering provided produces a ripple level of less than 100 millivolts rms when connected to a battery with an eight-hour capacity rating of four times the rectifier current rating.

The total dynamic response of the control circuitry permits all Micro ARE rectifiers to operate as power supplies.

REGULATION CURVE

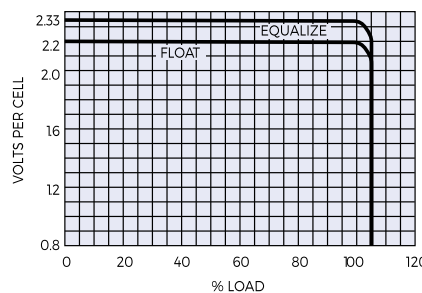

EFFICIENCY AND POWER FACTOR

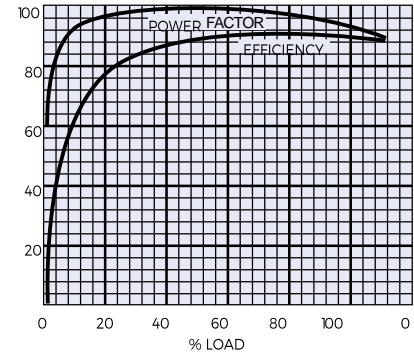

PRINCIPLES OF CONTROLLER FERRORESONANT OPERATION

The conventional ferroresonant transformer has inherently good regulation of output voltage against wide variations of input voltage. Its high reactance provides protection against overload and short circuit of the output. The output voltage does vary with changes in load and frequency. The output winding is on the same leg of the core as the resonant winding, and the resonant capacitor acts to maintain this core section at a high level of saturation, resulting in a constant voltage. To provide a precise constant voltage, it is necessary to control this level of core saturation. This is accomplished in the controlled ferro by shunting the resonant circuit with a switching device in series with an inductor. As shown in the block diagram, the unique Micro ARE circuit senses the start of the resonant capacitor charge cycle and switches the thyristor on to interrupt the cycle. The point of interruption is delayed by a signal fed back from the output to allow the voltage to rise to the preset level. In the event the current exceeds a preset level, the signal from the shunt overrides the voltage regulator to limit current; thus, precise control of voltage and current is maintained. If a fault occurs allowing a higher voltage to develop on the output, a sensing circuit causes the AC input breaker to shut down the charger.

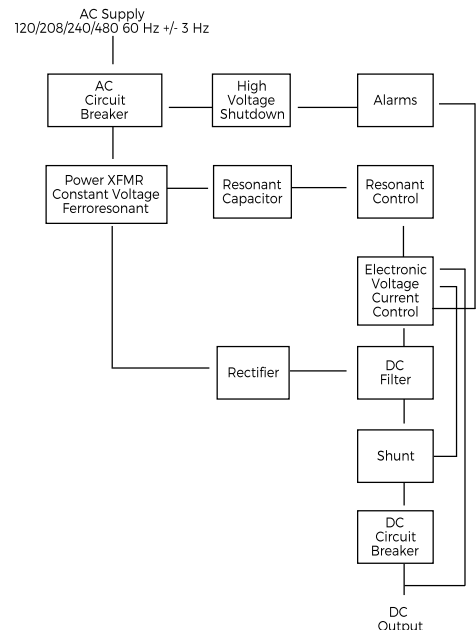

CURRENT LIMITING CIRCUIT

The current limiting circuit is factory set at 110% of rated DC output but can be adjusted down to 80% and up to 110%.

FLOAT AND EQUALIZE VOLTAGES

Both the float and equalize voltages are user adjustable to accommodate different battery types. Float voltages are adjustable from 2.00-2.32 Volts per Cell and the Equalize voltage is adjustable to a maximum of 2.45 Volts per Cell. (24-volt models: 24-28VDC; 48-volt models: 48- 59VDC; 130-volt models: 120-147VDC).

Float	24-27.8	48.0-55.7	120-139.2
EQ	Fit-29.4	Fit-59.0	Fit-147.0

TEMPERATURE COMPENSATION

The user-adjustable temperature compensation circuit will correct float and equalize voltages up to 2.0 mV per cell per C° [added for temperatures below 77°F (25°C) and subtracted for temperatures above 77°F (25°C)].

AMBIENT OPERATING TEMPERATURES

All Micro ARE rectifiers will operate at 110% of rated DC output, continuously in temperatures from 32°F to 122°F (0°C to 50°C) up to an altitude of 3,000 ft (1,000 m). De-rating of 3.6°F (2°C) for every 990 ft (300 m) over 3,300 ft (1,000 m) above sea level. These units can be safely stored for up to one year at temperatures ranging from -40°F to 185°F (-40°C to 85°C).

BATTERY ELIMINATOR OPERATION

All Micro ARE rectifiers will operate as a power supply without a battery at the following ripple levels:

- 24 and 48-volt models less than 30 mV rms
- 130-volt models less than 100 mV rms

MECHANICAL FEATURES

- Door opens approximately 90° for easy access to interior
- The control board is mounted on the rear of the door for easy access
- The interface board is mounted behind the door for easy access
- Serviceable components are accessible and removable from the front
- Input and output connections are easily accessible
- Holes with plastic covers are furnished for cables entry
- Cabinets can be relay rack, wall or floor mounted
- Cabinet has durable baked epoxy powder finish

CIRCUIT PROTECTION

- A shunt-trip AC circuit breaker is provided for input protection
- DC output circuit breaker
- An AC power failure alarm relay provides one set of Form C contacts that operate in case of an AC failure

STANDARD EQUIPMENT

- High DC voltage shutdown
- Redundant high-output voltage shutdown
- Digital display, 2 line by 20 characters, shows voltage and current in normal operation at one percent accuracy
- Float and equalize settings are adjusted via keypad
- AC power failure alarm relay with one set of form C contacts
- Rectifier failure alarm relay with one set of form C contacts

- High Voltage Shutdown failure alarm with one set of form C contacts
- Red Alarm LED and Green AC On LED display status of charger.
- Individual Alarm LEDs for quick visual reference
- No-charge alarm
- Load sharing circuit
- 0 to 255 hour equalize timer
- AC fail alarm
- Manual Ground Fault Voltage Meter
- Ground fault detection alarm (positive & negative)
- High DC voltage alarm
- Low DC voltage alarm
- Alarms have adjustable time delay, 1-300 seconds

OPTIONAL EQUIPMENT

- Blocking diode
- Lightning protection device
- Ground alarm detection cutoff switch
- Remote temperature probe
- DC output protection (MOVs)
- High interrupting Current DC breaker
- High interrupting Current AC breaker
- High battery temperature alarm (requires temperature probe)
- DNP3 Communications via Ethernet
- Floor stands: 24" and 36" heights
- Export packaging
- Drip top
- SIS wiring
- Alarm board with individual form C contacts for the summary, GND +, GND -, LVA, HVA, and NCA relays

TYPICAL DIMENSIONS

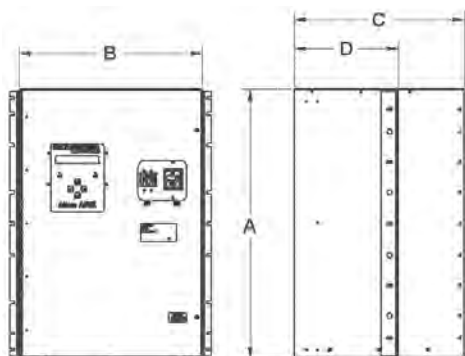

Cabinet	A	B	C	D
12	12.25 in 311 mm	17 in 432 mm	15 in 381 mm	6 in 152 mm
24	24.5 in 622 mm	17 in 432 mm	15 in 381 mm	6 in 152 mm
30	30 in 762 mm	20.5 in 521 mm	19 in 483 mm	11.6 in 295 mm

17 in (432 mm) wide cabinets can be used in 19 in (483 mm), 23 in (584 mm) or 30 in (762 mm) relay racks.

20.5 in (521 mm) wide cabinets can be used in 23 in (584 mm) or 30 in (762 mm) racks only.

Rack angles mount at rear for wall mounting.

Floor brackets are available for all models instead of relay rack mounting angles when ordered with charger.

24-volt output

Model	Input volts	AC amps	DC amps	Cabinet	Recommended DC cable size AWG	Circuit breaker DC	Approx. ship. wt.	
							lbs	kgs
ARE-M2406A	120/208/240	2/1.1/1	6	12	14	10	65	30
ARE-M2412A	120/208/240	4/2.3/2	12	12	10	20	72	33
ARE-M2425A	120/208/240	8.3/4.7/4.1	25	12	8	35	102	46
ARE-M2450A	120/208/240	16/9/8	50	24	4	70	162	74
ARE-M2450A	480	4	50	24	4	70	162	74

48-volt output

Model	Input volts	AC amps	DC amps	Cabinet	Recommended DC cable size AWG	Circuit breaker DC	Approx. ship. wt.	
							lbs	kgs
ARE-M4806A	120/208/240	4/2.3/2	6	12	14	10	72	33
ARE-M4812A	120/208/240	7/4/3.5	12	12	10	20	95	43
ARE-M4816A	120/208/240	8.5/5/4	16	12	10	20	102	46
ARE-M4830A	120/208/240	18/10/9	30	12	8	40	110	50
ARE-M4850A	120/208/240	30/17.6/15	50	24	4	70	192	87
ARE-M4850A	480	7.5	50	24	4	70	192	87

130-volt output

Model	Input volts	AC amps	DC amps	Cabinet	Recommended DC cable size AWG	Circuit breaker DC	Approx. ship. wt.	
							lbs	kgs
ARE-M13006A	120/208/240	8.5/5/4.5	6	12	14	10	100	46
ARE-M13012A	120/208/240	18/10/9	12	24	10	20	170	77
ARE-M13012A	480	5	12	24	10	20	170	77
ARE-M13016A	120/208/240	22/13/11	16	24	10	20	185	84
ARE-M13016A	480	6	16	24	10	20	185	84
ARE-M13025A	120/208/240	38/21/19	25	30	8	40	325	148
ARE-M13025A	480	8.5	25	30	8	40	325	148
ARE-M13035A	120/208/240	55/31/27	35	30	8	50	460	209
ARE-M13035A	480	13.5	35	30	8	50	460	209
ARE-M13050A	208/240/480	50/44/22	50	30	4	70	600	273

MET Labs is a Nationally Recognized Testing Laboratory (NRTL) recognized by OSHA. MET Labs certification indicates that a product fully meets UL and CSA standards. UL coordinates the standards writing and is only one of several NRTLs nationally recognized for testing and certification.